

# Type NS Disaster Resilient Ductile Iron Pipes & Fittings

SRDIP is engineered with advanced disaster resilience at its core. Designed to prevent pipe joint separation, it is capable of withstanding high levels of compression, extension, and angular deflection.



TECHNICAL GUIDE: **APF1.8B**

## Applications

Active fault line crossings

Liquefaction prone ground and subsidence.

Soft weak ground

Pipelines crossing bridge abutments

Water and waste water pipelines

Pipelines connected to critical service supply hubs: Hospitals, Civil Defence headquarters, government buildings etc.

Installation using Slip Lining and Pipe Jacking Methods

## Product Attributes

JIS G 5526: Ductile iron pipes

JIS G 5527: Ductile iron fittings

JIS G 5528: Epoxy-powder coating for interior of ductile iron pipes and fittings

JWWA G 112: Epoxy-powder coating for interior of ductile iron pipes and fittings for water supply

JWWA G 113: Ductile iron pipes for water supply

JWWA G 114: Ductile Iron fittings for water supply

ISO 16134 Earthquake and subsidence resistant design of ductile iron pipelines - Table 2 Classification of pipeline components

Flange drillings to AS4087 for water works purposes (PCD only) available upon special order request

# CONTENTS

## SPECIFICATIONS

1. Standard .....	3
2. Mechanical Properties .....	3
3. Coating and Lining .....	3
4. Water Pressure for Test and Holding Time.....	3
5. Type NS Joint Performance .....	4

## DATASHEET

1. Type NS ductile iron pipe (DN75-450) .....	5
2. Type NS ductile iron pipe (DN500-1000) .....	5
3. Type NS Socket and Spigot Cross with Socket Branch ..	6
4. Type NS Socket and Spigot Tee with Socket Branch .....	7
5. Type NS Reducer (Socket and Spigot Reducer).....	9
6. Type NS Reducer (Spigot and Socket Reducer).....	11
7. Type NS Socket and Spigot Bend 90° .....	13
8. Type NS Socket and Spigot Bend 45° .....	14
9. Type NS Socket and Spigot Bend 22 1/2° .....	15
10. Type NS Socket and Spigot Bend 11 1/4° .....	16
11. Type NS Socket and Spigot Bend 5 5/8° .....	17
12. Type NS Double Socket Bend .....	18
13. Type NS Sluice Valve Sub Pipe A1 .....	19
14. Type NS Sluice Valve Sub Pipe A2 .....	19
15. Type NS Socket and Spigot Tee with Flange (for air valve / for hydrant) .....	20
16. Type NS Tee with Flange for Shallow Embedding (for air valve/for hydrant) .....	22
17. Type NS Vortex Type Tee with Flange (for hydrant).....	22
18. Type NS drainage tee.....	23
19. Type NS Collar .....	24
20. Type NS Connecting Piece (Connecting Piece No.1).....	25
21. Type NS Connecting Piece (Connecting Piece No.2) ..	26

22. Type NS Cap .....	27
23. Type NS Stopper .....	28
24. Type NS Gland .....	29
25. Type NS Locking Ring.....	30
26. Type NS Liner .....	31
27. Type NS Spigot Ring for Cut Fitting (Rivet Type).....	33
28. Type NS Spigot Ring for Cut Fitting (Tapping Screw Type).....	34
29. Type NS Spigot Ring for Cut Fitting (Tapping Screw Type for Collar Jointing) .....	36
30. Type NS Bent Preventing Ring.....	37
31. Type NS T-Bolt and Nut.....	38
32. Type NS Rubber Gasket .....	39
33. Type NS Rubber for Centring Lock Ring .....	41
34. Type NS Rubber for Centring Liner.....	41
35. Type NS Backup Ring .....	42

## CONNECTING TO JIS FROM AS/NZS4087

Double flanged adaptor (JIS to AS4087).....	43
Flange spigot adaptor to Type NS pipe-socket .....	43

## TOOLSETS

Toolsets .....	44
----------------	----

## NEW ZEALAND CASE STUDIES

SRDIP Projects in New Zealand (as of February 2026).....	46
Kaitoke Flume Bridge (Wellington Water) .....	47
Heathcote Valley (Christchurch City Council) .....	47
Greenfield Water Supply (Clutha District Council) .....	47

## SPECIFICATIONS

### Standard

- JIS G 5526 : Ductile Iron Pipes
- JIS G 5527 : Ductile Iron Fittings
- JIS G 5528 : Epoxy-powder coating for interior of ductile iron pipes and fittings
- JWWA G 112 : Epoxy-powder coating for interior of ductile iron pipes and fittings for water supply
- JWWA G 113 : Ductile Iron Pipes
- JWWA G 114 : Ductile Iron Fittings

### Mechanical Properties

Tensile strength (MPa)	420 minimum
Elongation (%)	10 minimum
Brinell hardness (HBW)	230 maximum

### Coating and Lining

Nominal size	Pipe	Fitting
75 to 250	<ol style="list-style-type: none"><li>1. Zn-AlSiMn alloy spray: 200g/m<sup>2</sup></li><li>2. Sealing treatment: 50g/m<sup>2</sup></li><li>3. Synthetic resin coating: 200g/m<sup>2</sup></li></ol>	<ol style="list-style-type: none"><li>1. Aluminium-containing zinc rich paint: 150µm</li><li>2. Synthetic resin coating: 80µm</li></ol>
300 to 450	<ol style="list-style-type: none"><li>1. Zn-AlSiMn alloy spray: 200g/m<sup>2</sup></li><li>2. Sealing treatment: 50g/m<sup>2</sup></li><li>3. Synthetic resin coating: 200g/m<sup>2</sup></li></ol>	
500 to 800	<ol style="list-style-type: none"><li>1. Zn-AlSiMn alloy spray: 200g/m<sup>2</sup></li><li>2. Sealing treatment: 50g/m<sup>2</sup></li><li>3. Synthetic resin coating: 200g/m<sup>2</sup></li></ol>	
900 to 1000	<ol style="list-style-type: none"><li>1. Aluminium-containing zinc rich paint: 150µm</li><li>2. Synthetic resin coating: 80µm</li></ol>	

### Field Hydrostatic Tests and Procedures

The field water test procedures found within AS/NZS2566 Buried Flexible Pipelines Part 2: Installation. Appendix M, the clauses that apply are:

- The M2 Pre-Test Procedure,
- M3 Post Test Procedure and M4 Constant Pressure Test Procedure.

Please seek advice and approval from the Pipeline Designer, Asset Owner or Pipe Manufacturer prior to commencing field testing.

## Type NS Joint Performance

	Nominal size	Component performance	Class of ISO16134:2020
<b>Expansion/contraction performance</b>	75 to 1000	ffl1% of L (L: the pipe length, in mm)	S-1
<b>Slip-out resistance</b>	75 to 1000	3 D kN (D: the nominal diameter of pipe, in mm)	A
<b>Joint deflection angle</b>	75 to 250	8°	M-1
	300 to 450	6°	M-2
	500 to 1000	7°	M-1

Nominal size	Maximum expansion /contraction range when straight (mm)	Slip-out resistance force (kN)	Maximum bending angle in case of disaster	Allowable bending angle in installation
75	ffl45.5	225	8°	4°
100	ffl45.5	300	8°	4°
150	ffl60	450	8°	4°
200	ffl60	600	8°	4°
250	ffl60	750	8°	4°
300	ffl69	900	6°	3°
350	ffl70	1050	6°	3°
400	ffl71	1200	6°	3°
450	ffl73	1350	6°	3°
500	ffl75	1500	7°	3°20'
600	ffl75	1800	7°	2°50'
700	ffl75	2100	7°	2°30'
800	ffl75	2400	7°	2°10'
900	ffl75	2700	7°	2°00'
1000	ffl80	3000	7°	1°50'

# Datasheet

## 1. Type NS ductile iron pipe (DN75-450)

TABLE 1 Type NS ductile iron pipe (DN75-450)

Nominal size	Maximum expansion/contraction range when straight (mm)	Slip-out resistance force (kN)	Maximum bending angle in case of disaster	Allowable bending angle in installation
75	ffl45.5	225	8°	4°
100	ffl45.5	300	8°	4°
150	ffl60	450	8°	4°
200	ffl60	600	8°	4°
250	ffl60	750	8°	4°
300	ffl69	900	6°	3°
350	ffl70	1050	6°	3°
400	ffl71	1200	6°	3°
450	ffl73	1350	6°	3°
500	ffl75	1500	7°	3°20'
600	ffl75	1800	7°	2°50'
700	ffl75	2100	7°	2°30'
800	ffl75	2400	7°	2°10'
900	ffl75	2700	7°	2°00'
1000	ffl80	3000	7°	1°50'

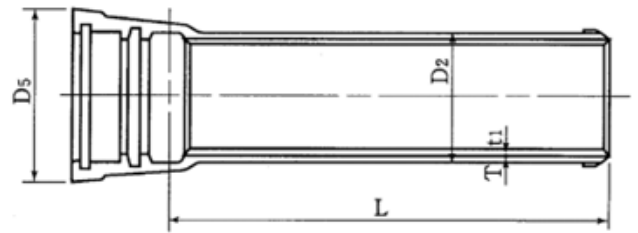

## 2. Type NS ductile iron pipe (DN500-1000)

TABLE 2 Type NS ductile iron pipe (DN500-1000)

Nominal size	Wall thickness of pipe	External diameter	External diameter of socket	Standardized length	Informative mass (kg)	Lining	
						Thickness t1	Mass (kg)
D	T DS	D2	D5	L	Iron part DS	Thickness t1	Mass (kg)
500	8.5	528.0	700	6000	699	6	135
600	10.0	630.8	804	6000	959	6	162
700	11.0	733.0	930	6000	1240	8	251
800	12.0	836.0	1039	6000	1550	8	286
900	13.0	939.0	1164	6000	1890	8	322
1000	14.5	1041.0	1273	6000	2320	10	445

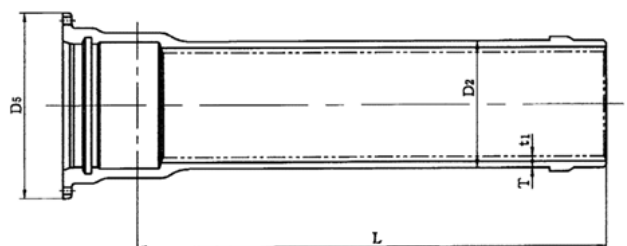

### 3. Type NS Socket and Spigot Cross with Socket Branch

**TABLE 3** Type NS Socket and Spigot Cross with Socket Branch

Nominal size (mm)		Wall thickness of fitting (mm)		Dimension of each part (mm)				Mass (kg)
D	d	T	t	H	I	J	L	
75	75	8.5	8.5	150	150	300	450	35.0
100	100	8.5	8.5	200	200	300	500	49.3
150	100	9.0	8.5	200	200	350	550	60.7
150	150	9.0	9.0	200	200	350	550	73.5
200	150	11.0	11.0	200	250	350	550	92.2
200	200	11.0	11.0	250	250	400	650	110
250	150	12.0	11.0	200	250	400	600	108
250	250	12.0	12.0	250	250	450	700	139

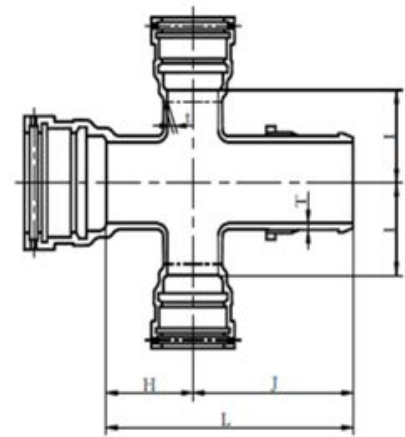

**TABLE 4** Type NS Socket and Spigot Cross with Socket Branch

Nominal size (mm)		Wall thickness of fitting (mm)		Dimension of each part (mm)				Mass (kg)
D	d	T	t	H	I	J	L	
300	200	12.5	11.0	170	345	370	540	140
300	300	12.5	12.5	235	235	430	665	165
350	250	13.0	12.0	205	370	405	610	175
350	350	13.0	13.0	265	265	465	730	200
400	300	14.0	12.5	235	285	450	685	206
400	400	14.0	14.0	295	295	515	810	253
450	300	14.5	12.5	235	310	450	685	226
450	450	14.5	14.5	320	320	540	860	293
500	400	15.0	14.0	480	460	850	1330	445
600	400	16.0	14.0	550	530	920	1470	561
700	500	17.0	15.0	620	600	980	1600	823
800	600	18.0	16.0	690	670	1030	1720	1040
900	700	19.0	17.0	770	750	1090	1860	1370

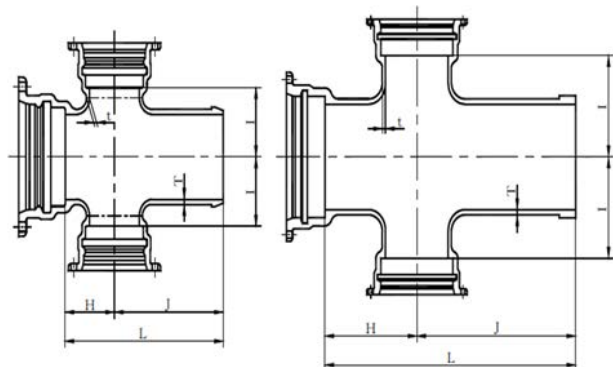

## 4. Type NS Socket and Spigot Tee with Socket Branch

TABLE 5 Type NS Socket and Spigot Tee with Socket Branch

Nominal size (mm)		Wall thickness of fitting (mm)		Dimension of each part (mm)				Mass (kg)
D	d	T	t	H	I	J	L	
75	75	8.5	8.5	150	150	300	450	25.3
100	75	8.5	8.5	150	200	300	450	31.1
100	100	8.5	8.5	200	200	300	500	35.6
1150	75	9.0	8.5	150	200	300	450	41.1
150	100	9.0	8.5	200	200	350	550	47.6
150	150	9.0	9.0	200	200	350	550	54.0
200	100	11.0	10.0	200	250	350	550	64.1
200	150	11.0	11.0	200	250	350	550	71.2
200	200	11.0	11.0	250	250	400	650	82.7
250	100	12.0	10.0	200	250	350	550	77.9
250	150	12.0	11.0	200	250	400	600	87.9
250	250	12.0	12.0	250	250	450	700	107
300	100	12.5	10.0	115	345	315	430	86.7
300	150	12.5	11.0	145	345	345	490	99.2
300	200	12.5	11.0	170	345	370	540	110
300	300	12.5	12.5	235	235	430	665	129
350	250	13.0	12.0	205	370	405	610	139
350	350	13.0	13.0	265	265	465	730	158
400	300	14.0	12.5	235	285	450	685	171
400	400	14.0	14.0	295	295	515	810	202
450	300	14.5	12.5	235	310	450	685	190
450	450	14.5	14.5	320	320	540	860	237

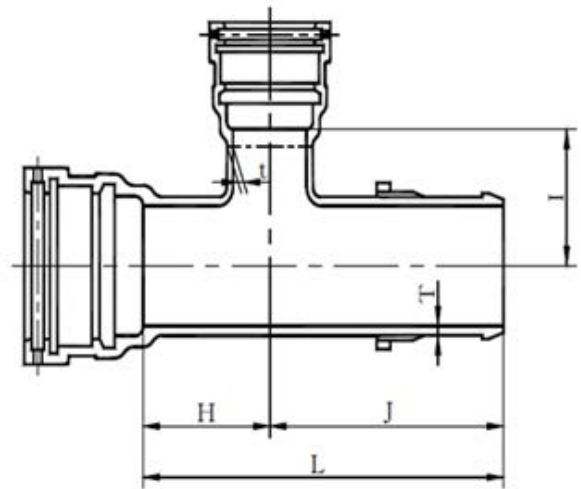

**TABLE 6** Type NS Socket and Spigot Tee with Socket Branch

Nominal size (mm)		Wall thickness of fitting (mm)		Dimension of each part (mm)				Mass (kg)
D	d	T	t	H	I	J	L	
500	350	15	13.0	480	460	850	1330	371
500	400	15	14.0	480	460	850	1330	382
500	450	15	14.5	480	460	850	1330	391
500	500	15	15.0	480	460	850	1330	429
600	400	16	14.0	550	530	920	1470	497
600	450	16	14.5	550	530	920	1470	505
600	500	16	15.0	550	530	920	1470	543
600	600	16	16.0	550	530	920	1470	569
700	450	17	17.0	620	600	980	1600	675
700	500	17	15.0	620	600	980	1600	713
700	600	17	16.0	620	600	980	1600	738
700	700	17	17.0	620	600	980	1600	799
800	500	18	18.0	690	670	1030	1720	880
800	600	18	16.0	690	670	1030	1720	905
800	700	18	17.0	690	670	1030	1720	965
800	800	18	18.0	690	670	1030	1720	1010
900	600	19	16.0	600	690	940	1540	969
900	700	19	17.0	770	750	1090	1860	1170
900	800	19	18.0	770	750	1090	1860	1210
900	900	19	19.0	770	750	1090	1860	1260
1000	600	20	16.0	680	770	990	1670	1180
1000	800	20	18.0	840	820	1140	1980	1430
1000	1000	20	20.0	840	820	1140	1980	1540

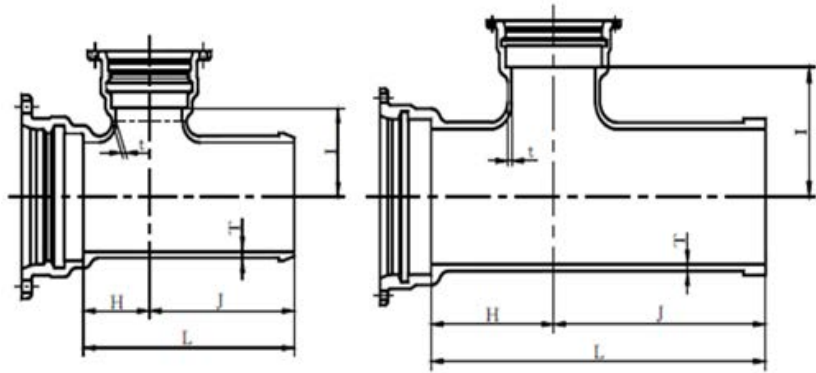

## 5. Type NS Reducer (Socket and Spigot Reducer)

TABLE 7 Type NS Reducer (Socket and Spigot Reducer)

Nominal size (mm)		Wall thickness of fitting (mm)		Dimension of each part (mm)		Mass (kg)
D	d	T	t	B	L1	
100	75	8.5	8.5	250	450	19.1
150	100	9.0	8.5	250	450	27.8
200	100	11.0	10.0	250	550	40.4
200	150	11.0	11.0	250	450	41.2
250	100	12.0	10.0	250	650	53.0
250	150	12.0	11.0	250	550	53.7
250	200	12.0	11.0	250	450	52.1
300	100	12.5	10.0	250	685	64.5
300	150	12.5	11.0	250	585	65.4
300	200	12.5	11.0	250	485	63.7
300	250	12.5	12.0	300	435	65.9
350	150	13.0	11.0	250	690	81.2
350	200	13.0	11.0	250	590	79.3
350	250	13.0	12.0	300	540	81.7
350	300	13.0	12.5	235	375	73.0
400	150	14.0	11.0	250	790	102
400	200	14.0	11.0	250	690	100
400	250	14.0	12.0	300	640	102
400	300	14.0	12.5	235	475	93.6
400	350	14.0	13.0	240	380	88.6
450	200	14.5	11.0	250	790	120
450	250	14.5	12.0	300	740	123
450	300	14.5	12.5	235	575	114
450	350	14.5	13.0	240	480	109
450	400	14.5	14.0	255	395	105

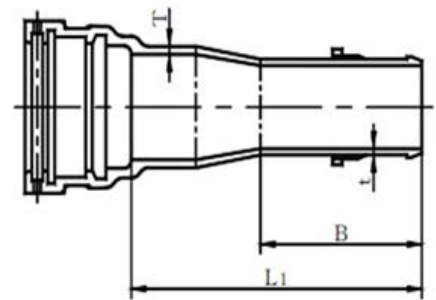

**TABLE 8** Type NS Reducer (Socket and Spigot Reducer)

Nominal size (mm)		Wall thickness of fitting (mm)		Dimension of each part (mm)		Mass (kg)
D	d	T	t	B	L1	
500	250	15	12.0	200	810	177
500	300	15	12.5	200	810	185
500	350	15	13.0	220	830	195
500	400	15	14.0	220	830	207
500	450	15	14.5	230	840	220
600	300	16	12.5	200	820	224
600	350	16	13.0	220	840	234
600	400	16	14.0	220	840	246
600	450	16	14.5	230	850	257
600	500	16	15.0	230	850	271
700	400	17	14.0	220	1050	355
700	450	17	14.5	230	1060	369
700	500	17	15.0	230	1060	385
700	600	17	16.0	230	1060	416
800	450	18	14.5	230	1070	435
800	500	18	15.0	230	1070	450
800	600	18	16.0	230	1070	479
800	700	18	17.0	240	1080	519
900	500	19	15.0	230	1080	526
900	600	19	16.0	230	1080	553
900	700	19	17.0	240	1090	590
900	800	19	18.0	240	1090	626
1000	600	20	16.0	230	1100	641
1000	700	20	17.0	240	1110	676
1000	800	20	18.0	240	1110	709
1000	900	20	19.0	260	1130	755

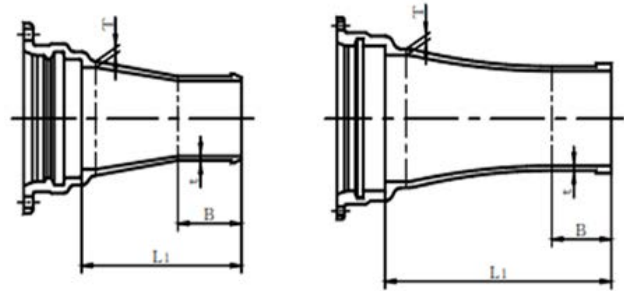

## 6. Type NS Reducer (Spigot and Socket Reducer)

TABLE 9 Type NS Reducer (Spigot and Socket Reducer)

Nominal size (mm)		Wall thickness of fitting (mm)		Dimension of each part (mm)		Mass (kg)
D	d	T	t	C	L2	
100	75	8.5	8.5	250	450	17.2
150	100	9.0	8.5	250	450	24.3
200	100	11.0	10.0	250	550	34.3
200	150	11.0	11.0	250	450	38.1
250	100	12.0	10.0	300	700	48.7
250	150	12.0	11.0	300	600	52.5
250	200	12.0	11.0	300	500	54.0
300	100	12.5	10.0	235	735	55.6
300	150	12.5	11.0	235	635	59.5
300	200	12.5	11.0	235	535	60.9
300	250	12.5	12.0	235	435	61.2
350	150	13.0	11.0	240	740	74.0
350	200	13.0	11.0	240	640	75.2
350	250	13.0	12.0	240	540	75.7
350	300	13.0	12.5	240	375	71.7
400	150	14.0	11.0	255	855	94.1
400	200	14.0	11.0	255	755	95.0
400	250	14.0	12.0	255	655	95.5
400	300	14.0	12.5	255	490	91.3
400	350	14.0	13.0	255	395	87.7
450	200	14.5	11.0	255	855	114
450	250	14.5	12.0	255	755	115
450	300	14.5	12.5	255	590	111
450	350	14.5	13.0	255	495	107
450	400	14.5	14.0	255	395	104

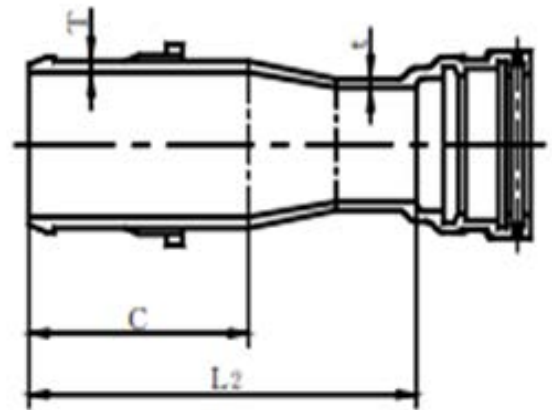

**TABLE 10** Type NS Reducer (Spigot and Socket Reducer)

Nominal size (mm)		Wall thickness of fitting (mm)		Dimension of each part (mm)		Mass (kg)
D	d	T	t	C	L2	
500	250	15	12.0	230	800	130
500	300	15	12.5	230	810	145
500	350	15	13.0	230	810	156
500	400	15	14.0	230	820	174
500	450	15	14.5	230	830	189
600	300	16	12.5	230	810	170
600	350	16	13.0	230	810	181
600	400	16	14.0	230	820	197
600	450	16	14.5	230	830	212
600	500	16	15.0	230	840	256
700	400	17	14.0	240	1030	265
700	450	17	14.5	240	1040	282
700	500	17	15.0	240	1050	329
700	600	17	16.0	240	1060	375
800	450	18	14.5	240	1040	318
800	500	18	15.0	240	1050	364
800	600	18	16.0	240	1060	408
800	700	18	17.0	240	1070	489
900	500	19	15.0	260	1070	413
900	600	19	16.0	260	1080	454
900	700	19	17.0	260	1090	533
900	800	19	18.0	260	1100	599
1000	600	20	16.0	260	1080	501
1000	700	20	17.0	260	1090	577
1000	800	20	18.0	260	1100	640
1000	900	20	19.0	260	1110	713

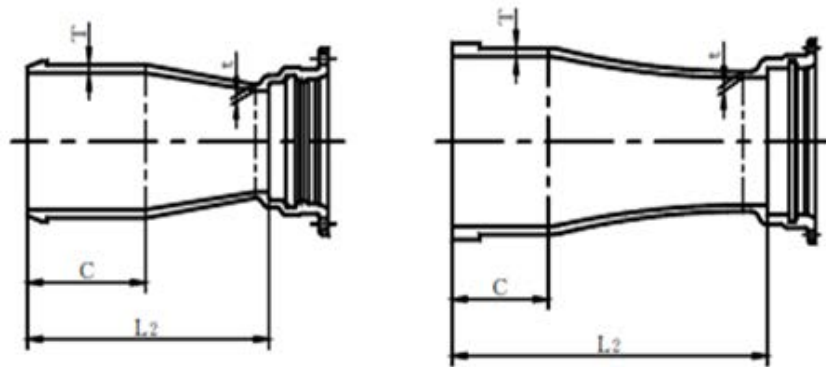

## 7. Type NS Socket and Spigot Bend 90°

TABLE 11 Type NS Socket and Spigot Bend 90°

Nominal size (mm)	Wall thickness of fitting (mm)	Dimension of each part (mm)				Mass (kg)
		D	T	R	L1	
75	8.5	70	200	300	470	15.9
100	8.5	95	200	350	509	22.0
150	9.0	145	250	400	588	35.7
200	11.0	195	300	450	666	56.2
250	12.0	240	350	500	747	78.5
300	12.5	230	265	465	631	88.7
350	13.0	280	320	520	720	115
400	14.0	335	375	590	821	153
450	14.5	405	445	660	931	192

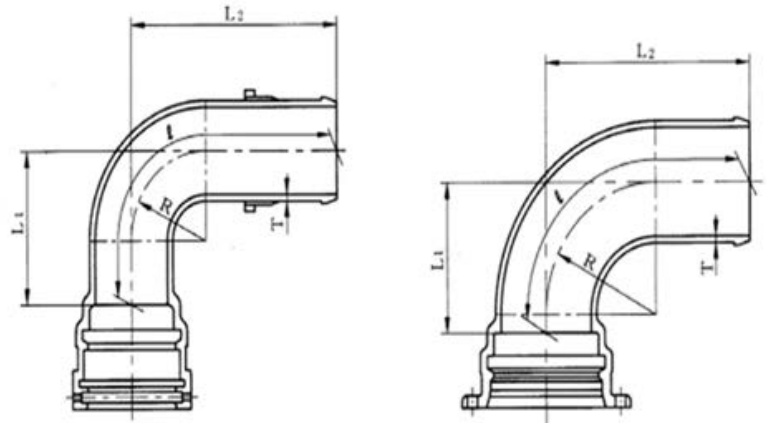
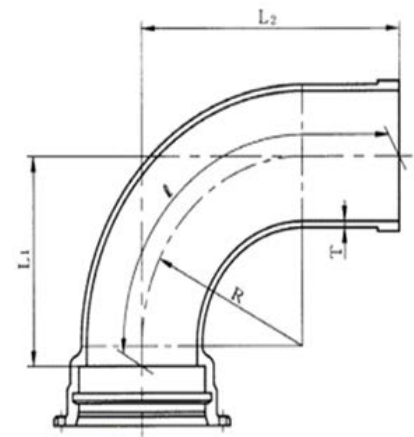

TABLE 12 Type NS Socket and Spigot Bend 90°

Nominal size (mm)	Wall thickness of fitting (mm)	Dimension of each part (mm)				Mass (kg)
		D	T	R	L1	
500	15	485	555	805	1152	288
600	16	580	655	900	1306	397
700	17	680	760	1050	1518	580
800	18	775	855	1160	1682	756
900	19	870	955	1405	1987	1020
1000	20	965	1050	1515	2151	1270



## 8. Type NS Socket and Spigot Bend 45°

**TABLE 13** Type NS Socket and Spigot Bend 45°

Nominal size (mm)		Wall thickness of fitting (mm)	Dimension of each part (mm)				Mass (kg)
D	T	R	L1	L2	I		
75	8.5	70	150	250	397	14.7	
100	8.5	95	150	300	446	20.7	
150	9.0	145	150	300	444	31.1	
200	11.0	195	200	350	542	49.7	
250	12.0	240	200	400	590	67.5	
300	12.5	230	130	330	450	72.9	
350	13.0	280	155	355	498	91.2	
400	14.0	335	175	395	556	118	
450	14.5	405	205	425	613	144	

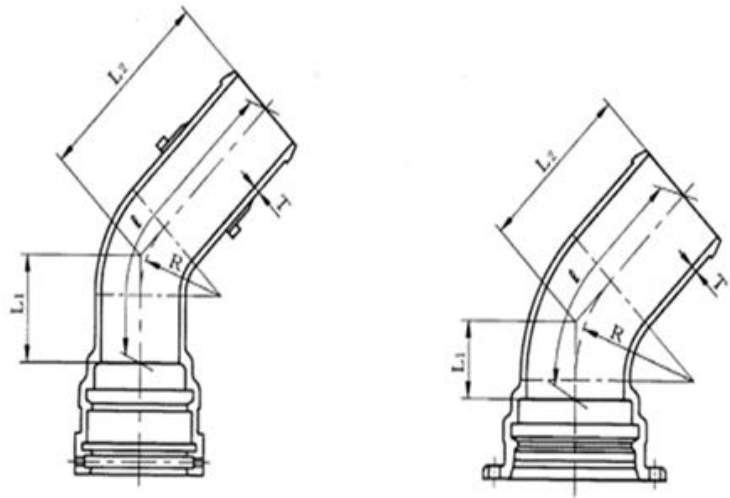

**TABLE 14** Type NS Socket and Spigot Bend 45°

Nominal size (mm)		Wall thickness of fitting (mm)	Dimension of each part (mm)				Mass (kg)
D	T	R	L1	L2	I		
500	15	485	275	520	774	223	
600	16	580	315	560	850	296	
700	17	680	365	655	991	436	
800	18	775	400	705	1072	555	
900	19	870	445	895	1303	751	
1000	20	965	485	950	1393	920	

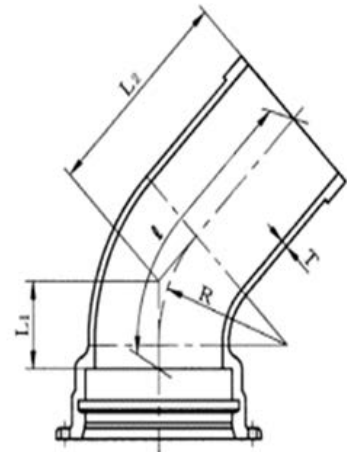

## 9. Type NS Socket and Spigot Bend 22 1/2°

TABLE 15 Type NS Socket and Spigot Bend 22 1/2°

Nominal size (mm)	Wall thickness of fitting (mm)	Dimension of each part (mm)				Mass (kg)
		D	T	R	L1	
75	8.5	70	100	250	350	14.0
100	8.5	95	150	250	400	19.8
150	9.0	145	150	300	449	31.3
200	11.0	195	150	300	449	44.9
250	12.0	240	150	350	499	61.1
300	12.5	230	85	280	364	65.4
350	13.0	280	95	295	389	79.7
400	14.0	335	105	320	423	101
450	14.5	405	120	335	453	120

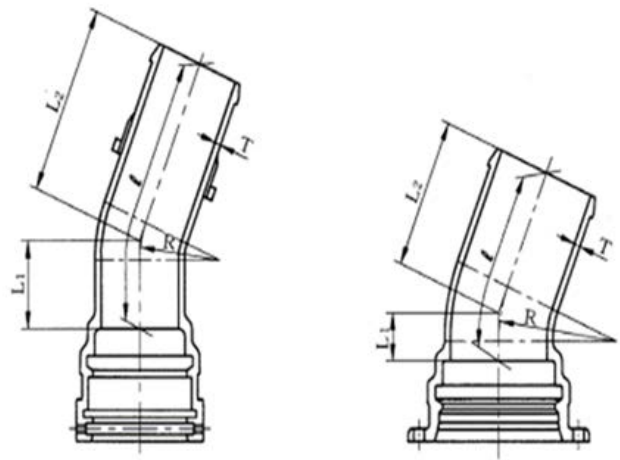
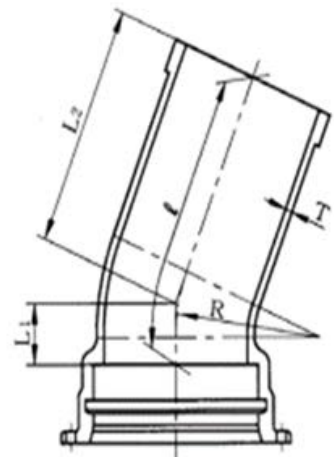

TABLE 16 Type NS Socket and Spigot Bend 22 1/2°

Nominal size (mm)	Wall thickness of fitting (mm)	Dimension of each part (mm)				Mass (kg)
		D	T	R	L1	
500	15	485	170	615	783	224
600	16	580	190	625	812	288
700	17	680	215	750	962	428
800	18	775	235	820	1051	548
900	19	870	255	975	1226	720
1000	20	965	275	1040	1310	882



## 10. Type NS Socket and Spigot Bend 11 1/4°

**TABLE 17** Type NS Socket and Spigot Bend 11 1/4°

Nominal size (mm)	Wall thickness of fitting (mm)	Dimension of each part (mm)				Mass (kg)
		D	T	R	L1	
75	8.5	70	100	250	350	14.0
100	8.5	95	100	250	350	18.7
150	9.0	145	100	250	350	28.0
200	11.0	195	150	300	450	45.0
250	12.0	240	150	300	450	57.7
300	12.5	230	60	260	320	61.5
350	13.0	280	65	270	335	74.0
400	14.0	335	70	290	360	93.0
450	14.5	405	80	295	375	108

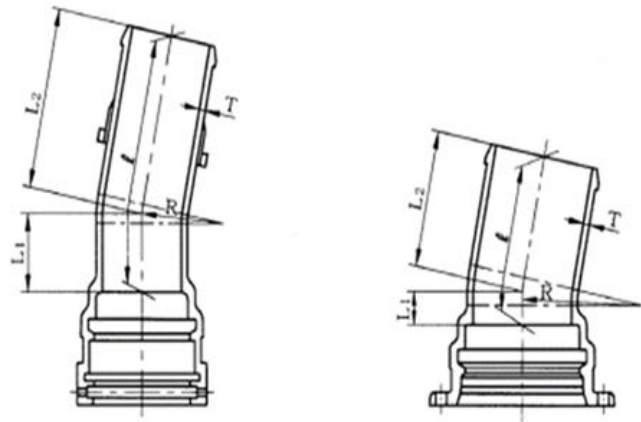

**TABLE 18** Type NS Socket and Spigot Bend 11 1/4°

Nominal size (mm)	Wall thickness of fitting (mm)	Dimension of each part (mm)				Mass (kg)
		D	T	R	L1	
500	15	485	170	615	785	225
600	16	580	190	620	810	287
700	17	680	215	745	960	427
800	18	775	235	820	1055	549
900	19	870	255	970	1224	720
1000	20	965	275	1035	1309	882

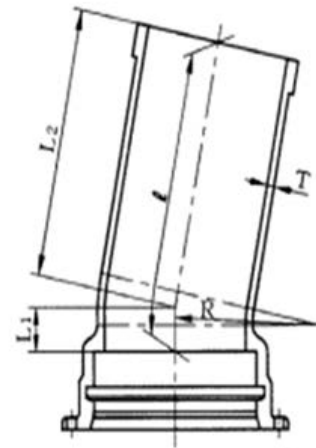

## 11. Type NS Socket and Spigot Bend 5 5/8°

TABLE 19 Type NS Socket and Spigot Bend 5 5/8°

Nominal size (mm)	Wall thickness of fitting (mm)	Dimension of each part (mm)				Mass (kg)
		D	T	R	L1	
75	8.5	70	100	250	350	14.0
100	8.5	95	100	250	350	18.7
150	9.0	145	100	250	350	28.0
200	11.0	195	150	300	450	45.0
250	12.0	240	150	300	450	57.7
300	12.5	230	50	245	295	59.4
350	13.0	280	50	255	305	70.8
400	14.0	335	55	270	325	88.5
450	14.5	405	60	275	335	102

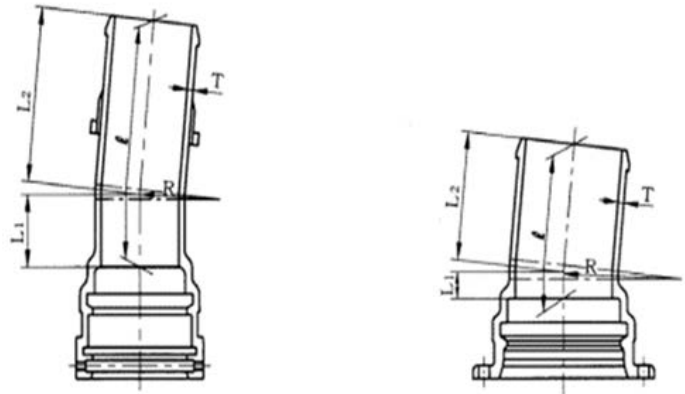
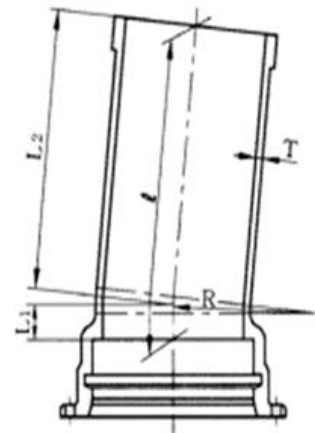

TABLE 20 Type NS Socket and Spigot Bend 5 5/8°

Nominal size (mm)	Wall thickness of fitting (mm)	Dimension of each part (mm)				Mass (kg)
		D	T	R	L1	
500	15	485	170	615	785	225
600	16	580	190	620	810	287
700	17	680	215	745	960	427
800	18	775	235	820	1055	549
900	19	870	255	970	1225	720
1000	20	965	275	1035	1310	882



## 12. Type NS Double Socket Bend

TABLE 21 Type NS Double Socket Bend

Nominal size (mm)	Wall thickness of fitting (mm)	45°				22 1/2°			
		Dimension of each part (mm)			Mass (kg)	Dimension of each part (mm)			Mass (kg)
D	T	R	L1	I		R	L1	I	
75	8.5	70	150	297	21.1	70	100	200	19.5
100	8.5	95	150	296	28.2	95	150	300	28.3
150	9.0	145	150	294	42.1	145	150	299	42.3
200	11.0	195	200	392	62.8	195	150	299	58.0
250	12.0	240	200	390	78.7	240	150	299	72.3

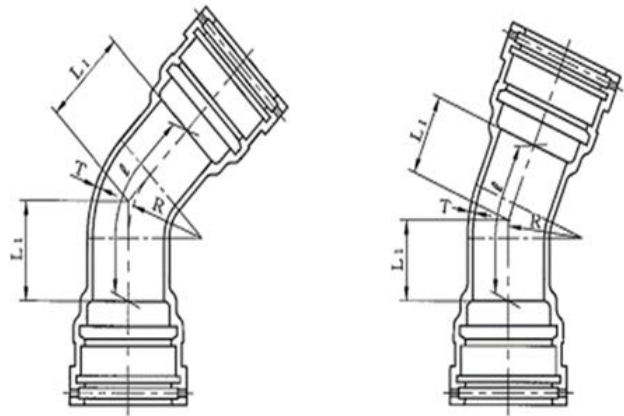
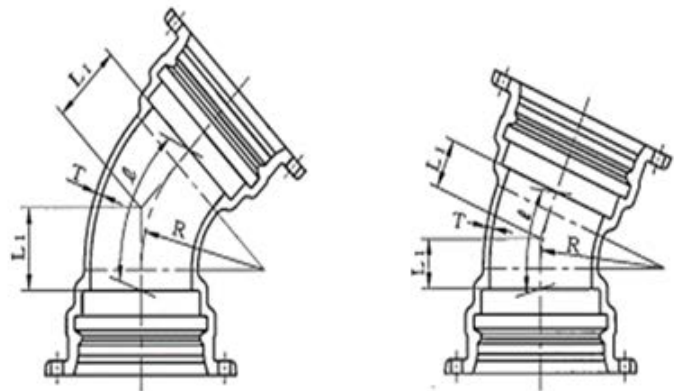

TABLE 22 Type NS Double Socket Bend

Nominal size (mm)	Wall thickness of fitting (mm)	45°				22 1/2°			
		Dimension of each part (mm)			Mass (kg)	Dimension of each part (mm)			Mass (kg)
D	T	R	L1	I		R	L1	I	
350	13.0	280	155	298	108	280	95	189	96.9
400	14.0	335	175	336	136	335	105	208	119
450	14.5	405	205	393	163	405	120	238	139



### 13. Type NS Sluice Valve Sub Pipe A1

TABLE 23 Type NS Sluice Valve Sub Pipe A1

Nominal size (mm)		Wall thickness of fitting (mm)		Dimension of each part (mm)				Mass (kg)			
D	d	T	t	B	I	J	L	Model 2			
								7.5K	10K	16K	20K
400	100	14.0	10	155	115	350	270	110	106	124	131
450	100	14.5	10	160	115	375	275	129	123	147	156
500	100	15.0	10	250	250	360	500	210	204	234	243
600	100	16.0	11	280	280	440	560	274	272	309	321
700	150	17.0	12	310	310	490	620	385	387	435	481
800	150	18.0	13	330	330	550	660	485	485	552	634
900	200	19.0	14	370	370	610	740	617	611	690	791
1000	200	20.0	15	400	400	670	800	750	747	857	-

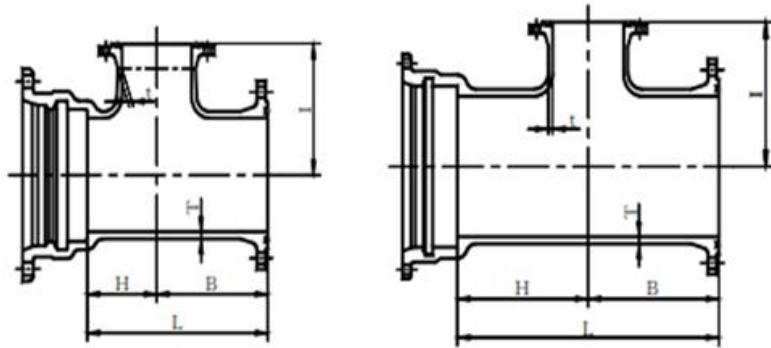

### 14. Type NS Sluice Valve Sub Pipe A2

TABLE 24 Type NS Sluice Valve Sub Pipe A2

Nominal size (mm)		Wall thickness of fitting (mm)		Dimension of each part (mm)				Mass (kg)			
D	d	T	t	B	I	J	L	Model 2			
								7.5K	10K	16K	20K
400	100	14.0	10	155	350	335	490	92.8	88.6	106	114
450	100	14.5	10	160	375	335	495	110	105	129	137
500	100	15.0	10	250	360	560	810	180	175	204	213
600	100	16.0	11	280	440	600	880	243	241	278	290
700	150	17.0	12	310	490	620	930	321	322	371	416
800	150	18.0	13	330	550	630	960	402	403	469	551
900	200	19.0	14	370	610	670	1040	516	510	589	690
1000	200	20.0	15	400	670	700	1100	628	626	736	-

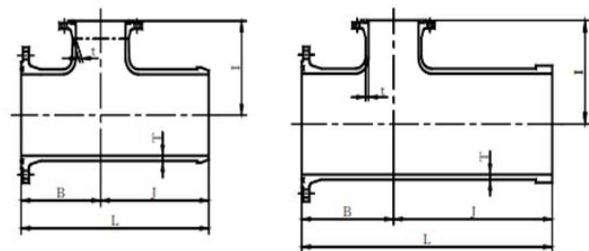

## 15. Type NS Socket and Spigot Tee with Flange (for air valve/for hydrant)

TABLE 25 Type NS Socket and Spigot Tee with Flange

Nominal size (mm)		Wall thickness of fitting (mm)		Dimension of each part (mm)				Mass (kg)			
D	d	T	t	H	I	J	L	Model 2			
								7.5K	10K	16K	20K
75	75	8.5	8.5	150	200	300	450	21.6	20.1	20.8	21.1
100	75	8.5	8.5	150	200	300	450	26.6	25.1	25.8	26.1
150	75	9.0	8.5	150	250	300	450	37.4	35.9	36.6	36.9
150	100	9.0	8.5	200	250	350	550	42.1	40.3	41.5	41.8
200	75	11.0	10.0	200	250	350	550	56.2	54.7	55.4	55.7
200	100	11.0	10.0	200	250	350	550	57.5	55.7	57.0	57.3
250	75	12.0	10.0	200	300	350	550	71.1	69.6	70.3	70.6
250	100	12.0	10.0	200	300	350	550	72.5	70.8	72.0	72.3

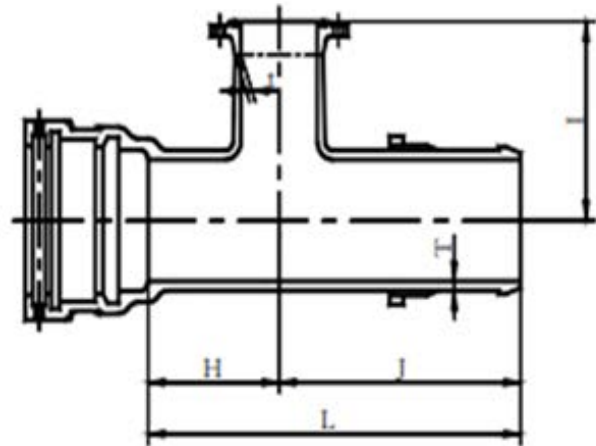

**TABLE 26** Type NS Socket and Spigot Tee with Flange

Nominal size (mm)		Wall thickness of fitting (mm)		Dimension of each part (mm)				Mass (kg)			
D	d	T	t	H	I	J	L	Model 2			
								7.5K	10K	16K	20K
300	75	12.5	10.0	105	300	300	405	75.3	73.8	74.5	74.8
300	100	12.5	10.0	115	300	315	430	78.8	77.0	78.3	78.6
350	75	13.0	10.0	105	325	305	410	88.3	86.8	87.5	87.8
350	100	13.0	10.0	115	325	320	435	92.3	90.5	91.7	92.1
400	75	14.0	10.0	105	350	320	425	108	106	107	107
400	100	14.0	10.0	115	350	335	450	113	111	112	112
450	75	14.5	10.0	105	375	320	425	122	121	122	122
450	100	14.5	10.0	115	375	335	450	128	126	127	127
500	75	15.0	10.0	230	360	560	790	231	229	230	230
500	100	15.0	10.0	230	400	560	790	233	231	232	232
600	75	16.0	11.0	240	410	570	810	293	291	292	292
600	100	16.0	11.0	240	450	570	810	295	293	294	294
700	75	17.0	12.0	260	480	580	840	400	399	400	400
700	100	17.0	12.0	260	480	580	840	401	400	401	401
800	75	18.0	13.0	270	520	590	860	490	489	489	490
800	100	18.0	13.0	270	520	590	860	491	489	491	491
800	600	18.0	16.0	690	670	1030	1720	838	838	874	885
900	100	19.0	14.0	300	590	620	920	608	606	607	608
900	600	19.0	16.0	600	690	940	1540	903	903	939	950
1000	150	20.0	15.0	320	640	640	960	732	731	733	734
1000	600	20.0	16.0	680	770	990	1670	1110	1110	1150	1160

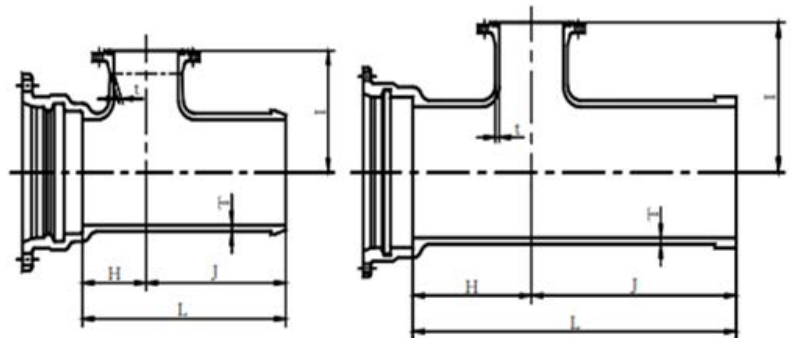

## 16. Type NS Tee with Flange for Shallow Embedding (for air valve/for hydrant)

**TABLE 27** Type NS Tee with Flange for Shallow Embedding

Nominal size (mm)		Wall thickness of fitting (mm)		Dimension of each part (mm)				Mass (kg)
D	d	T	t	H	I	J	L	Model 2
								7.5K
75	75	8.5	8.5	200	105	350	550	21.7
100	75	8.5	8.5	200	120	350	550	27.4
150	75	9.0	8.5	200	170	350	550	39.4
150	100	9.0	8.5	250	170	400	650	43.6
200	75	11.0	10.0	200	200	400	600	57.9
200	100	11.0	10.0	250	200	400	650	61.5
250	75	12.0	10.0	200	230	400	600	73.5
250	100	12.0	10.0	250	230	400	650	77.8

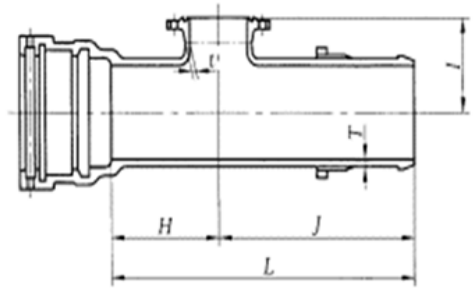

## 17. Type NS Vortex Type Tee with Flange (for hydrant)

**TABLE 28** Type NS Vortex Type Tee with Flange

Nominal size (mm)		Wall thickness of fitting (mm)		Dimension of each part (mm)				Mass (kg)
D	d	T	t	H	I	J	L	Model 2
								7.5K
75	75	8.5	8.5	150	250	300	450	26.1
100	75	8.5	8.5	150	250	300	450	31.1
150	75	9.0	8.5	150	280	300	450	43.3
150	100	9.0	8.5	200	280	350	550	48.9
200	75	11.0	10.0	200	300	350	550	64.2
200	100	11.0	10.0	200	300	350	550	66.6
250	75	12.0	10.0	200	330	350	550	80.2
250	100	12.0	10.0	200	330	350	550	82.6
300	75	12.5	10.0	105	350	460	565	100
300	100	12.5	10.0	115	350	475	590	105
350	75	13.0	10.0	105	380	465	570	118
350	100	13.0	10.0	115	380	480	595	123

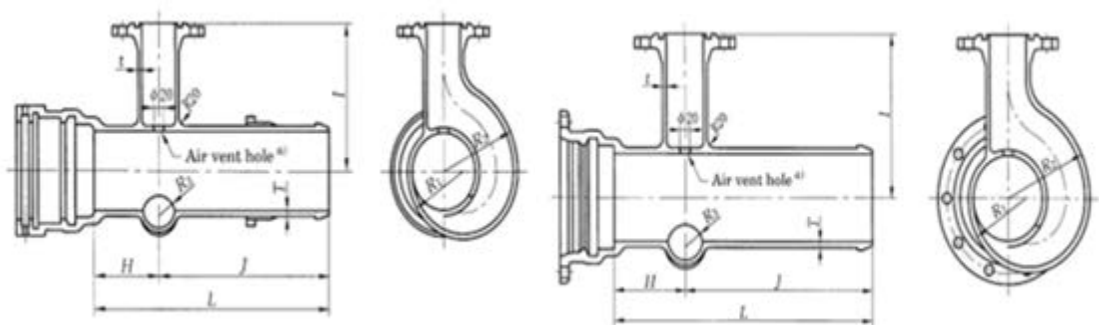

## 18. Type NS drainage tee

TABLE 29 Type NS drainage tee

Nominal size (mm)		Wall thickness of fitting (mm)		Dimension of each part (mm)			Mass (kg)
D	d	T	t	H	I	L	
200	100	11	10	200	250	400	78.2
250	100	12	10	200	250	400	94.0

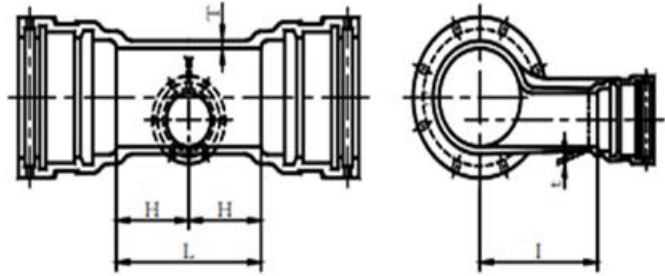
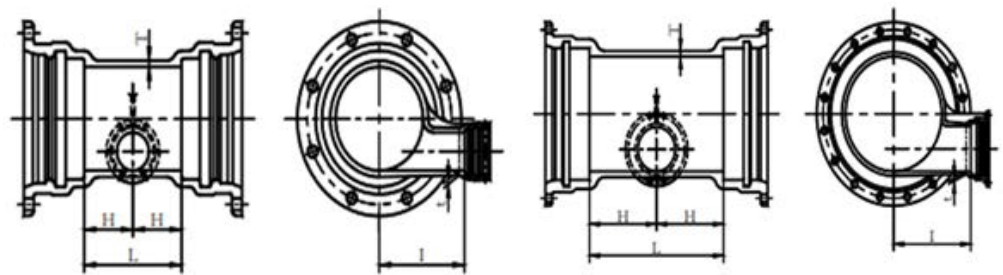

TABLE 30 Type NS drainage tee

Nominal size (mm)		Wall thickness of fitting (mm)		Dimension of each part (mm)			Mass (kg)
D	d	T	t	H	I	L	
300	100	12.5	10	140	270	280	106
350	150	13.0	11	175	300	350	136
400	150	14.0	11	175	325	350	160
450	200	14.5	12	200	360	400	193
500	200	15.0	13	280	350	560	298
600	200	16.0	13	290	400	580	368
700	300	17.0	15	350	450	700	550
800	300	18.0	15	360	500	720	667
900	300	19.0	15	370	550	740	798
1000	400	20.0	16	440	600	880	1010



## 19. Type NS Collar

TABLE 31 Type NS Collar

Nominal size (mm)		Wall thickness of fitting (mm)	Dimension of each part (mm)	Mass (kg)
D	T	L		
75	12	550	28.2	
100	12	550	34.9	
150	13	600	52.2	
200	13	600	65.7	
250	13	600	78.6	
300	14	620	103	
350	14	620	118	
400	15	620	140	
450	16	620	161	
500	17	650	212	
600	18	650	261	
700	19	800	385	
800	21	800	477	
900	22	800	568	
1000	23	800	662	

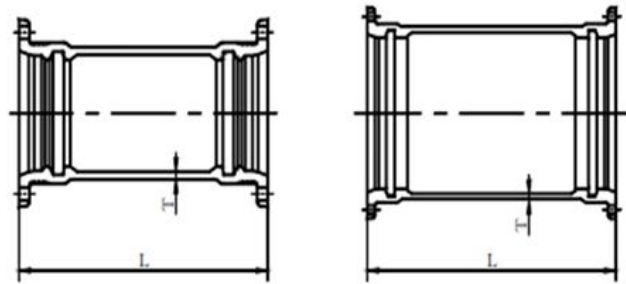

## 20. Type NS Connecting Piece (Connecting Piece No.1)

TABLE 32 Type NS Connecting Piece (Connecting Piece No.1)

Nominal size (mm)	Wall thickness of fitting (mm)	Standardized length (mm)	Mass (kg)			
			Model 2			
			7.5K	10K	16K	20K
D	T	L1				
75	8.5	150	14.2	12.7	13.5	13.8
100	8.5	150	18.5	16.7	18.0	18.3
150	9.0	150	27.2	26.5	28.7	29.9
200	11.0	150	36.8	35.5	38.8	40.0
250	12.0	200	50.8	50.1	55.9	59.0
300	12.5	135	59.1	56.3	64.6	68.0
350	13.0	135	71.0	65.6	78.3	82.2
400	14.0	140	85.6	83.2	99.8	107
450	14.5	140	100	96.9	119	128
500	15.0	170	147	143	171	180
600	16.0	250	198	199	234	246
700	17.0	250	274	277	323	367
800	18.0	250	339	340	405	486
900	19.0	250	411	406	482	582
1000	20.0	250	483	482	589	-

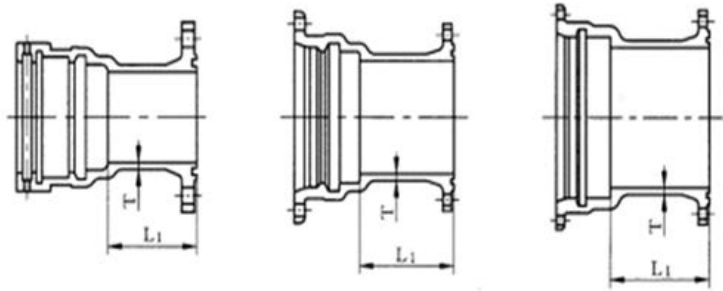

## 21. Type NS Connecting Piece (Connecting Piece No.2)

**TABLE 33** Type NS Connecting Piece (Connecting Piece No.2)

Nominal size (mm)	Wall thickness of fitting (mm)	Standardized length (mm)	Mass (kg)			
			Model 2			
D	T	L1	7.5K	10K	16K	20K
75	8.5	350	9.48	7.99	8.71	9.00
100	8.5	350	12.1	10.3	11.6	11.9
150	9.0	400	19.4	18.8	20.9	22.1
200	11.0	400	28.9	27.6	30.7	32.1
250	12.0	400	39.6	38.9	44.7	47.8
300	12.5	410	49.7	46.9	55.2	58.6
350	13.0	435	64.3	58.9	71.6	75.5
400	14.0	465	81.7	79.3	95.9	103
450	14.5	470	98.7	95.1	118	126
500	15.0	750	164	160	188	197
600	16.0	750	207	207	243	254
700	17.0	750	262	264	310	355
800	18.0	750	322	324	388	469
900	19.0	800	409	404	479	579
1000	20.0	800	476	475	582	-

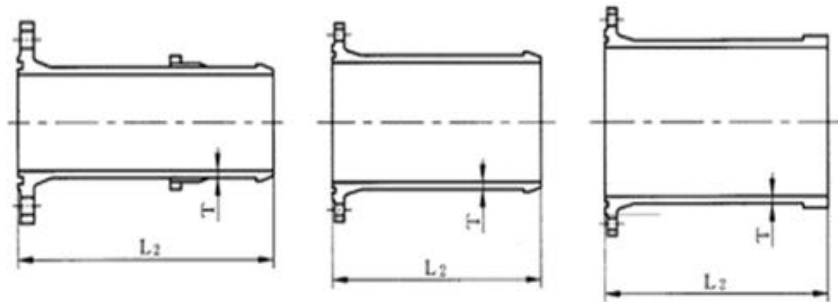

## 22. Type NS Cap

TABLE 34 Type NS Cap

Nominal size (mm)	Dimension of each part (mm)			Dimension of hanger (mm)		Mass (kg)
	D	T1	P	r	t	
75	18.0	133	-	-	10.9	
100	18.0	133	-	-	13.9	
150	18.0	133	-	-	20.3	
200	18.0	133	-	-	27.0	
250	19.5	133	-	-	34.8	
300	23.0	141	30	20	48.9	
350	24.0	141	30	20	59.6	
400	25.0	143	35	20	74.1	
450	26.0	143	35	20	87.7	

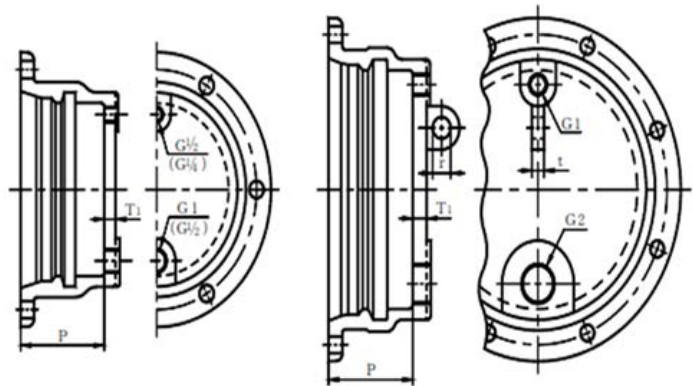
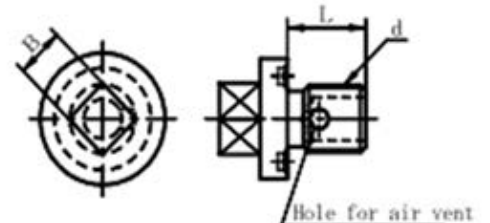

TABLE 35 Type NS Cap

Nominal designation of thread (mm)	Bolt for air vent and drainage		Seal ring	
	Dimension of each part (mm)		Dimension of each part (mm)	
d	B	L	t	d4
G1/4	12	21	5.0	19
G1/2	14	22	5.0	21
G1	22	27	5.0	35
G2	25	30	5.7	60

Bolt for air vent and drainage  
(SUS304 of JIS G 4303)



Seal ring

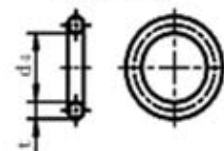

## 23. Type NS Stopper

TABLE 36 Type NS Stopper

Nominal size (mm)	Dimension of each part (mm)	Dimension of each hanger (mm)			Number of ribs	Mass (kg)
		D	T1	p		
500	15	118	35	20	6	88.5
600	16	119	35	20	6	130
700	17	137	40	30	6	187
800	18	143	40	30	6	278
900	19	144	40	30	8	369
1000	20	147	45	40	8	473

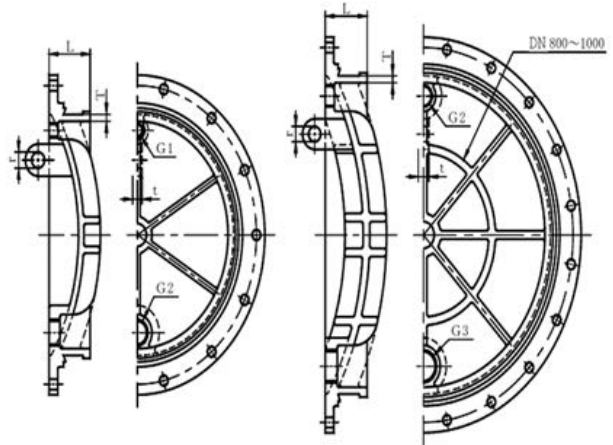
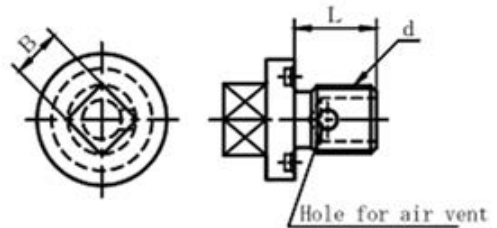

TABLE 37 Type NS Cap

Nominal designation of thread (mm)	Bolt for air vent and drainage		Seal ring	
	Dimension of each part (mm)		Dimension of each part (mm)	
d	B	L	t	d4
G1	22	27	5.0	35
G2	25	30	5.7	60
G3	29	40	5.7	90

Bolt for air vent and drainage  
(SUS304 of JIS G 430)



Seal ring

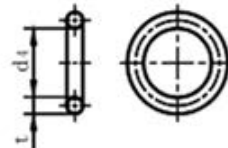

## 24. Type NS Gland

TABLE 38 Type NS Gland

Nominal size (mm)	Dimension of each part (mm)					Number of holes for bolt	Mass (kg)
	D	D <sub>3</sub>	D <sub>4</sub>	D <sub>5</sub>	E		
75	97.0	186	224	19	18	4	3.63
100	122.0	209	255	23	20	4	4.55
150	173.0	264	310	23	20	6	6.80
200	224.0	318	364	23	20	6	8.29
250	275.6	370	416	23	20	8	10.4
300	326.8	431	477	23	20	8	12.9
350	378.0	482	528	23	21	10	15.7
400	429.6	536	582	23	22	12	18.9
450	480.8	587	633	23	23	12	21.5
500	532.0	654	700	23	24	14	21.2
600	634.8	758	804	23	25	14	26.2
700	738.0	876	930	27	26	16	35.3
800	841.0	985	1039	27	28	20	42.3
900	944.0	1098	1164	33	29	20	53.4
1000	1047.0	1207	1273	33	30	20	62.6

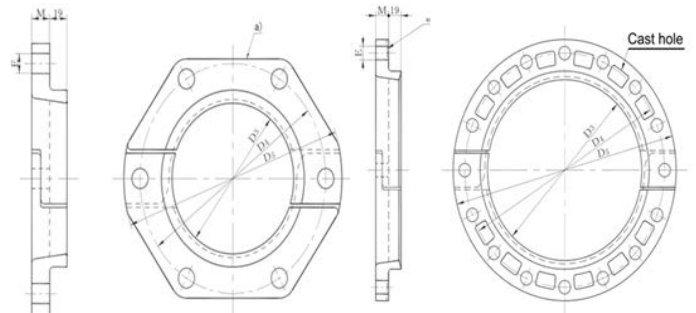

## 25. Type NS Locking Ring

**TABLE 39** Type NS Locking Ring

Nominal size (mm)	Dimension of each part (mm)			Mass (kg)
	H	M	R	
75	8	15	54.5	0.154
100	9	15	68.0	0.225
150	9	15	93.5	0.400
200	9	15	119.0	0.523
250	9	15	144.8	0.649
300	11	20	160.4	1.34
350	11	20	186.0	1.55
400	11	20	211.8	1.77
450	11	20	237.4	1.98

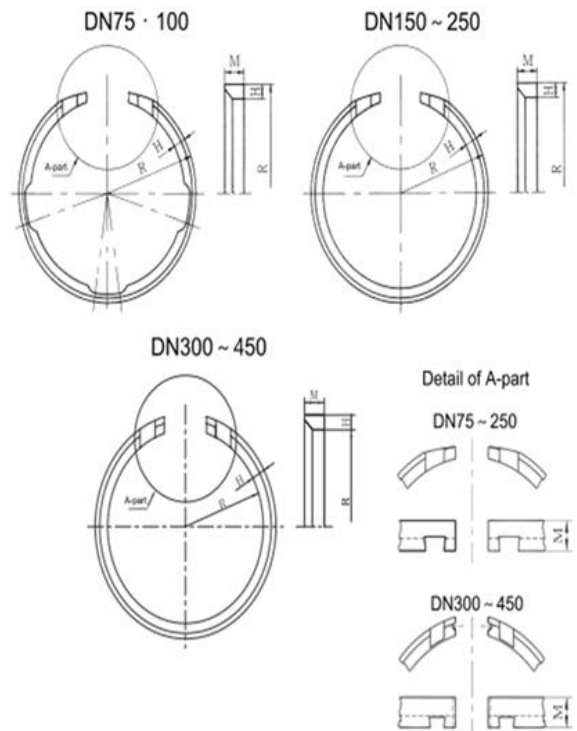

**TABLE 40** Type NS Locking Ring

Nominal size (mm)	Dimension of each part (mm)			Mass (kg)
	H	M	R	
500	17.5	25.0	262	4.51
600	17.5	25.0	310	5.39
700	19.5	30.5	360	8.87
800	20.5	30.5	411	10.5
900	21.5	30.5	461	12.2
1000	23.5	35.5	511	17.2

DN500 ~ 1000

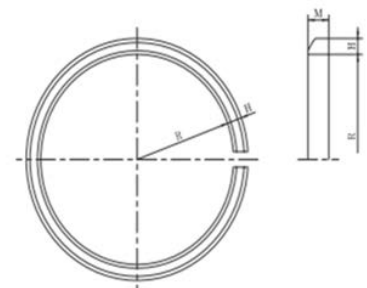

## 26. Type NS Liner

TABLE 41 Type NS Liner

Nominal size (mm)	Dimension of each part (mm)			Mass (kg)
	D <sub>9</sub>	A	B	
75	93.0	72	9	1.22
100	118.0	72	9	1.59
150	169.0	101	9	3.27
200	220.0	101	11	5.22
250	271.6	101	11	6.50
300	323.8	122	20	9.64
350	375.0	124	21	12.2
400	426.6	124	22	15.0
450	477.8	127	24	18.8

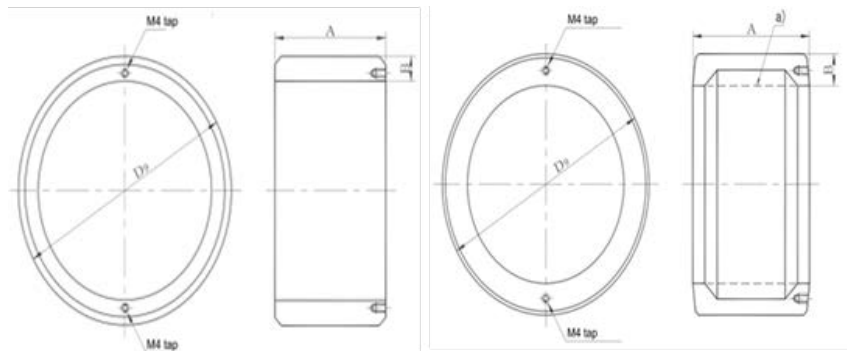

**TABLE 42** Type NS Liner

Nominal size (mm)	Liner				Fastening plate for liner	Bolt for liner	Bolt for centring a liner	
	D <sub>9</sub> (mm)	A (mm)	B (mm)	Mass of assembly (kg)	Number	Number	Dimension L	Number
500	143	27	270.0	31.3	2	4	32	4
600	143	27	321.5	38.5	3	6	32	6
700	145	29	374.0	48.4	3	6	41	6
800	145	31	426.0	59.0	4	8	41	8
900	145	31	477.0	68.0	4	8	44	8
1000	146	31	528.0	78.1	4	8	44	8

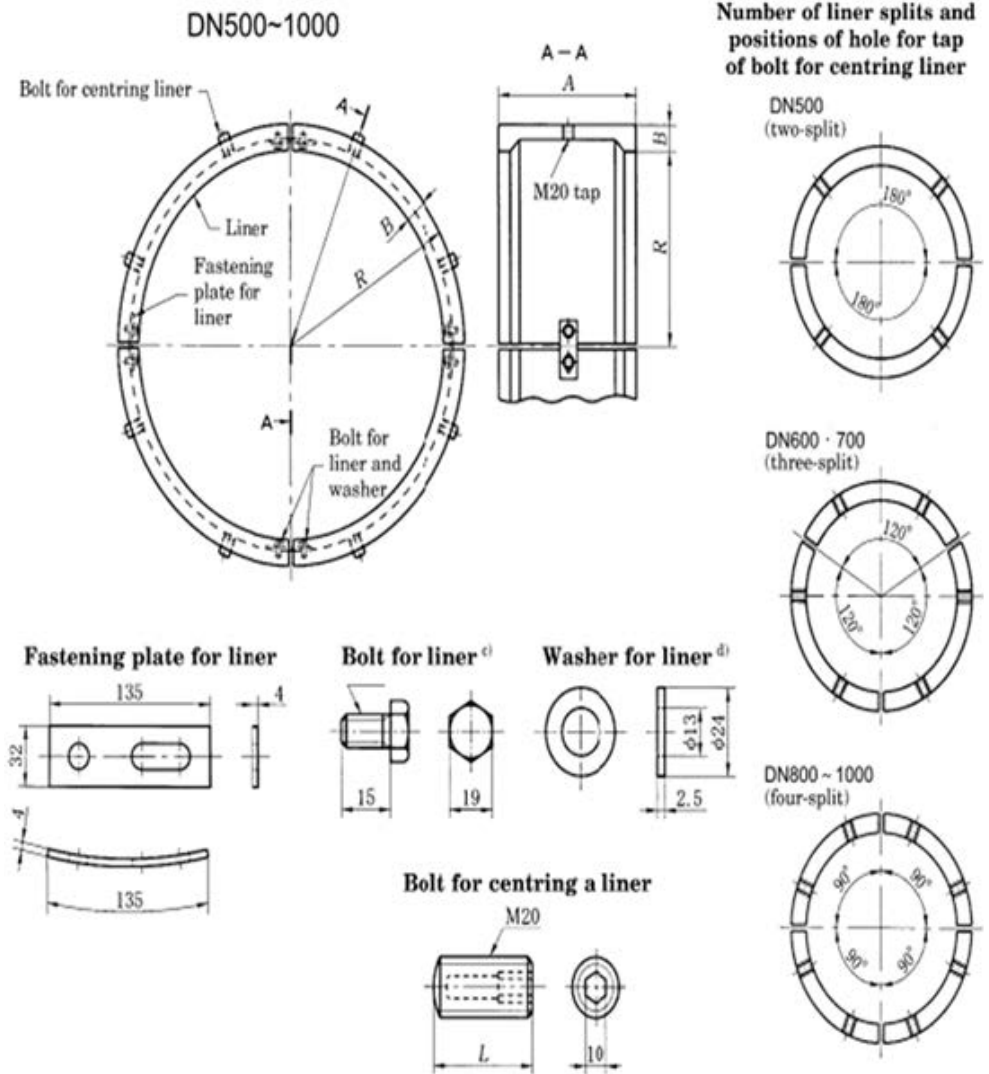

## 27. Type NS Spigot Ring for Cut Fitting (Rivet Type)

TABLE 43 Type NS Spigot Ring for Cut Fitting (Rivet Type)

Nominal size (mm)	Spigot ring			Connecting plate for spigot ring			Mass of assembly (kg)
	$D_1$ (mm)	$m$ (mm)	$t_1$ (mm)	$m_1$ (mm)	$S$ (mm)	$t_3$ (mm)	
75	87.0	18.9	4.5	14.9	66.5	2	0.121
100	111.3	18.9	5.0	14.9	68.0	2	0.173
150	161.2	18.9	5.0	14.9	71.0	2	0.244
200	211.0	18.9	5.0	14.9	74.5	2	0.318
250	261.5	18.9	5.0	14.9	77.5	2	0.387
300	308.5	19.4	5.0	15.4	92.0	2	0.457
350	358.0	19.4	5.0	15.4	98.0	2	0.529
400	408.0	19.4	5.0	15.4	101.0	2	0.600
450	458.0	19.4	5.0	15.4	104.0	2	0.672

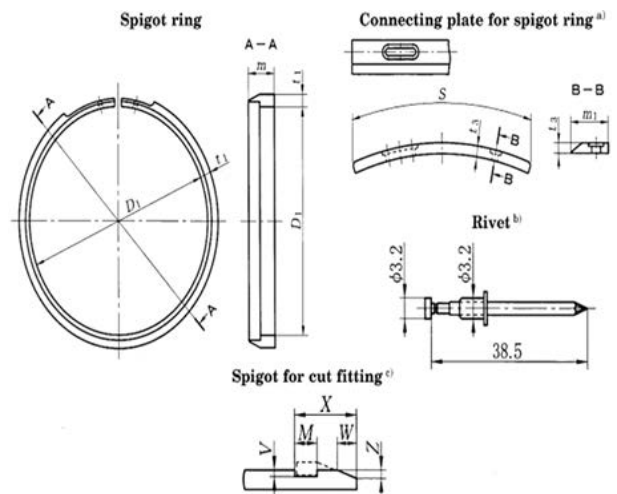
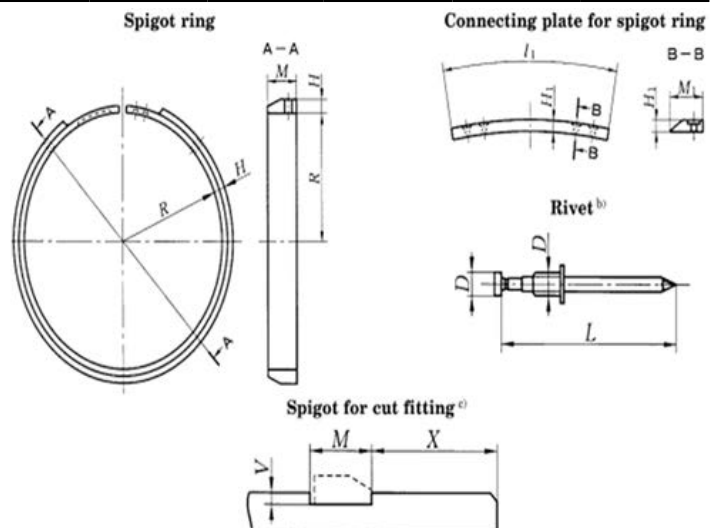

TABLE 44 Type NS Spigot Ring for Cut Fitting (Rivet Type)

Nominal size (mm)	Spigot Ring for Cut Fitting							Rivet	
	Spigot ring			Connecting plate for spigot ring			Mass of assembly (kg)	D (mm)	L (mm)
	H (mm)	M (mm)	R (mm)	H <sub>1</sub> (mm)	l <sub>1</sub> (mm)	M <sub>1</sub> (mm)			
500	7	20	259	3	111	19	1.53	3.2	38.5
600	7	20	310	3	111	19	1.83	3.2	38.5
700	10	25	360	5	114	24	3.65	4.0	40.0
800	10	25	411	5	114	24	4.17	4.0	40.0
900	10	25	463	5	114	24	4.69	4.0	40.0
1000	11	30	513	5	114	29	6.79	4.0	40.0



## 28. Type NS Spigot Ring for Cut Fitting (Tapping Screw Type)

TABLE 45 Type NS Spigot Ring for Cut Fitting (Tapping Screw Type)

Nominal size (mm)	Spigot ring					Spigot		
	$D_1$ (mm)	$h_1$ (mm)	$m$ (mm)	$t_1$ (mm)	Mass of assembly (kg)	$M$ (mm)	$V$ (mm)	$X$ (mm)
75	94.5	2.5	34	11.0	0.232	4.5	2.5	15
100	119.5	3.0	34	11.5	0.333	4.5	2.5	15
150	170.0	3.0	34	11.5	0.504	4.5	2.5	15
200	221.0	3.0	34	11.5	0.662	4.5	2.5	15
250	272.6	3.0	34	11.5	0.838	4.5	2.5	15

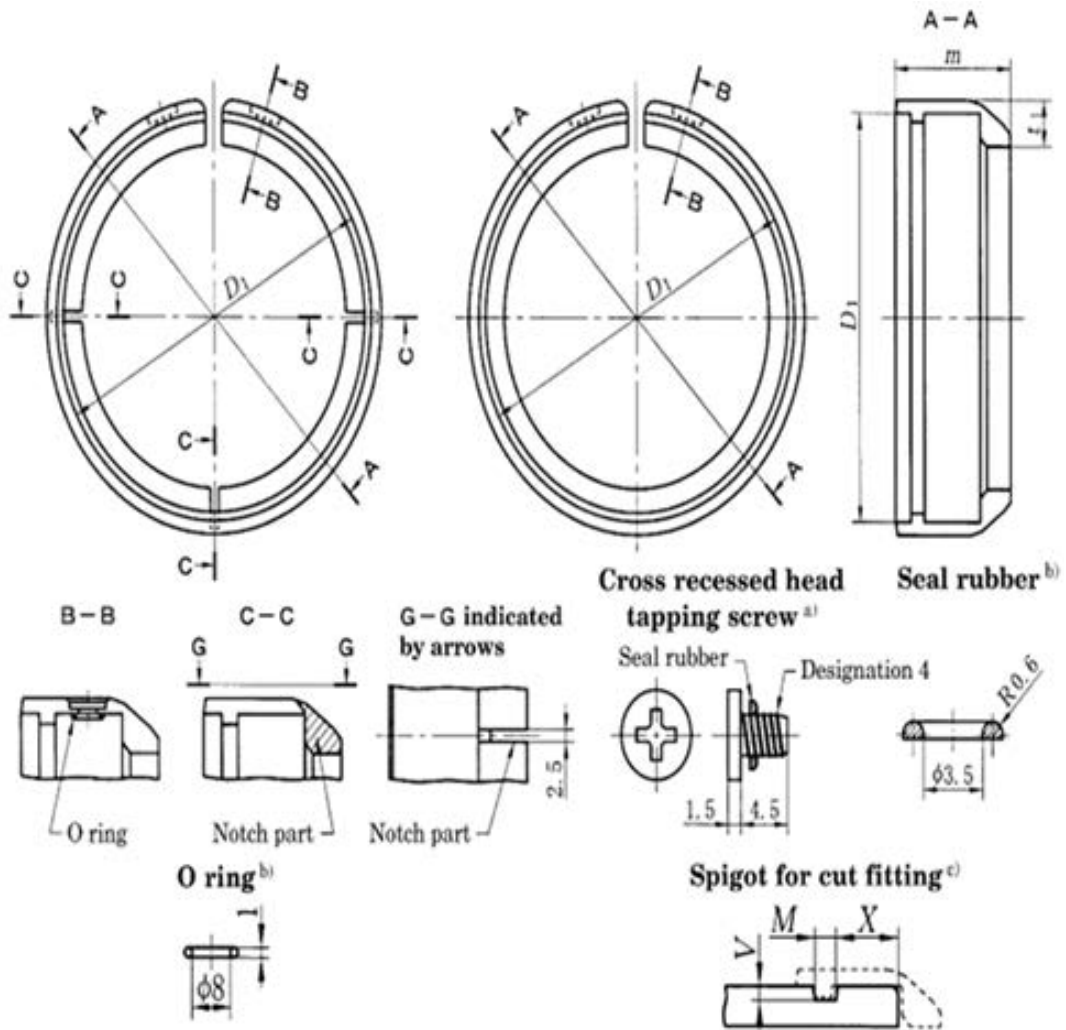

**TABLE 46** Type NS Spigot Ring for Cut Fitting (Tapping Screw Type)

Nominal size (mm)	Spigot ring for cut fitting					Spigot		
	$D_1$ (mm)	$h_1$ (mm)	$m$ (mm)	$t_1$ (mm)	Mass of assembly (kg)	$M$ (mm)	$V$ (mm)	$X$ (mm)
300	322.8	3	38	11.5	1.01	4.5	2.5	20
350	374.0	3	38	11.5	1.17	4.5	2.5	20
400	425.6	3	38	12.5	1.41	4.5	2.5	20
450	476.8	3	38	13.0	1.62	4.5	2.5	20

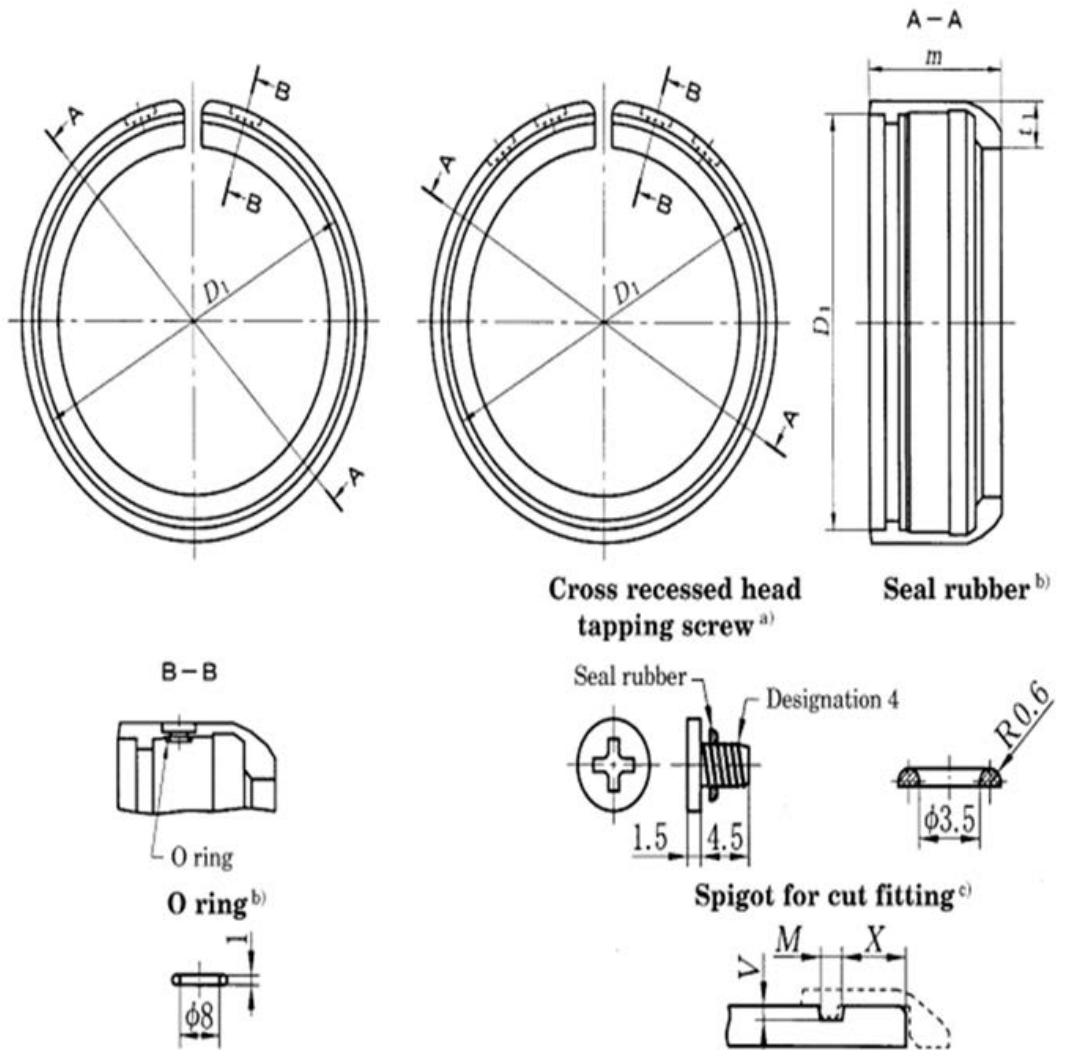

## 29. Type NS Spigot Ring for Cut Fitting (Tapping Screw Type for Collar Jointing)

**TABLE 47** Type NS Spigot Ring for Cut Fitting (Tapping Screw Type for Collar Jointing)

Nominal size (mm)	Spigot ring				Spigot		
	$D_1$ (mm)	$h_1$ (mm)	$m$ (mm)	Mass of assembly (kg)	$M$ (mm)	$V$ (mm)	$X$ (mm)
75	93.0	2.5	28.7	0.144	4.5	2.5	50
100	118.0	3.0	28.7	0.217	4.5	2.5	50
150	169.0	3.0	28.7	0.317	4.5	2.5	50
200	220.0	3.0	28.7	0.414	4.5	2.5	50
250	271.6	3.0	28.7	0.513	4.5	2.5	50
300	322.8	3.0	28.7	0.608	4.5	2.5	50
350	374.0	3.0	28.7	0.707	4.5	2.5	50
400	425.6	3.0	28.7	0.805	4.5	2.5	50
450	476.8	3.0	28.7	0.904	4.5	2.5	50

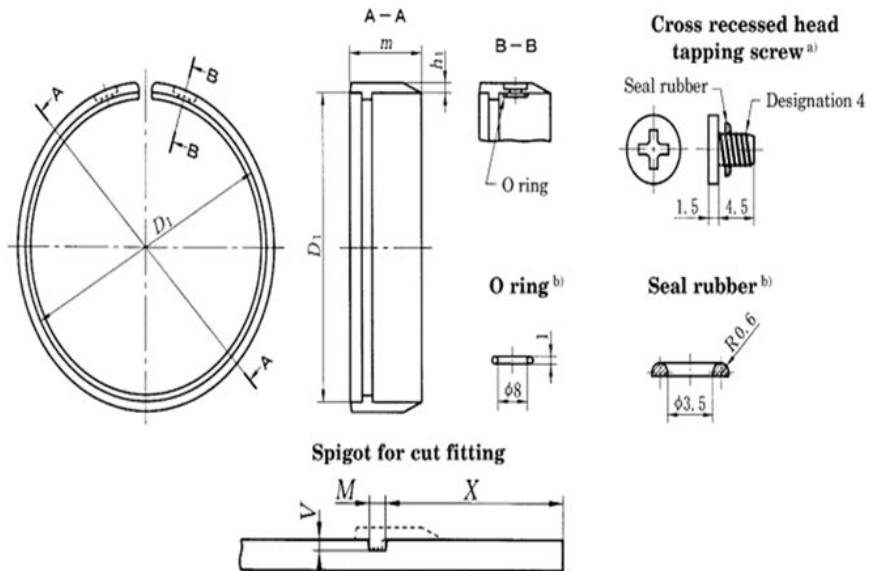

## 30. Type NS Bent Preventing Ring

TABLE 48 Type NS Bent Preventing Ring

Nominal size (mm)	Bend preventing ring					Set Bolt				Rubber for fixing bend preventing ring			
	D <sub>o</sub> (mm)	H (mm)	M (mm)	Number in assembly	Mass of assembly (kg)	Designation d	B	l	Number in assembly	H (mm)	M (mm)	L (mm)	Numbering assembly
75	93.0	7.5	10	4	0.198	M10	5	15	4	9	10	15.5	4
100	118.0	7.5	16	3	0.402	M12	6	18	6	9	16	19.0	3
150	169.0	7.5	16	3	0.566	M12	6	18	6	9	16	19.0	3
200	220.0	9.0	24	4	1.09	M16	8	22	8	9	24	13.0	4
250	271.6	9.0	24	4	1.34	M16	8	22	8	9	24	13.0	4

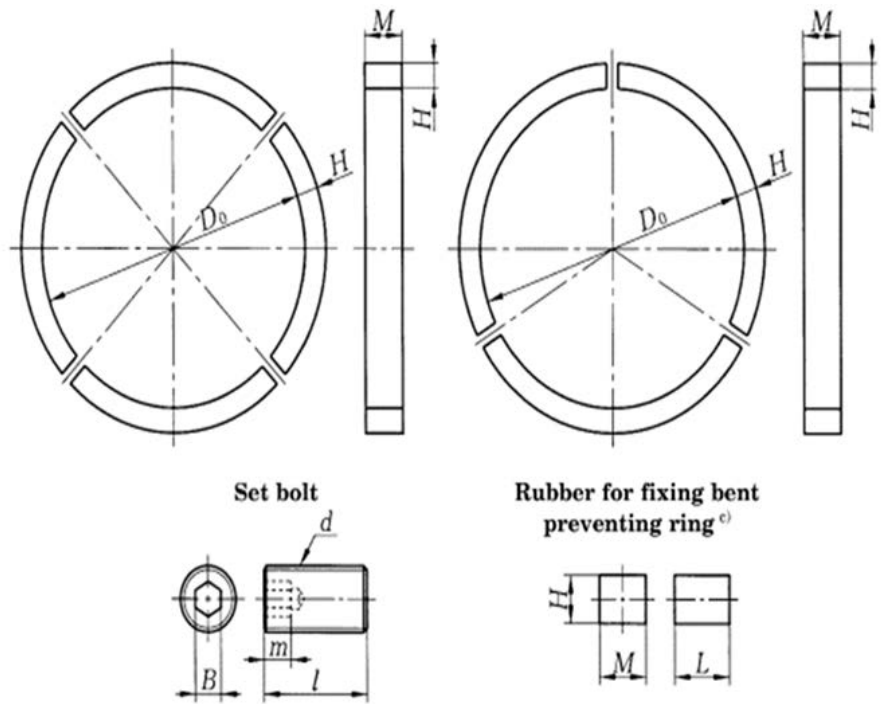

### 31. Type NS T-Bolt and Nut

TABLE 49 Type NS T-Bolt and Nut

Nominal size (mm)	Nominal size of bolt d	B (mm)	C (mm)	E (kg)	Number in assembly
75	M16	24	100	70	4
100	M20	30	100	70	4
150	M20	30	100	70	6
200	M20	30	100	70	6
250	M20	30	100	70	8
300	M20	30	100	70	8
350	M20	30	100	70	10
400	M20	30	110	75	12
450	M20	30	110	75	12
500	M20	30	125	80	14
600	M20	30	125	80	14
700	M24	36	145	100	16
800	M24	36	145	100	20
900	M30	46	155	110	20
1000	M30	46	155	110	20

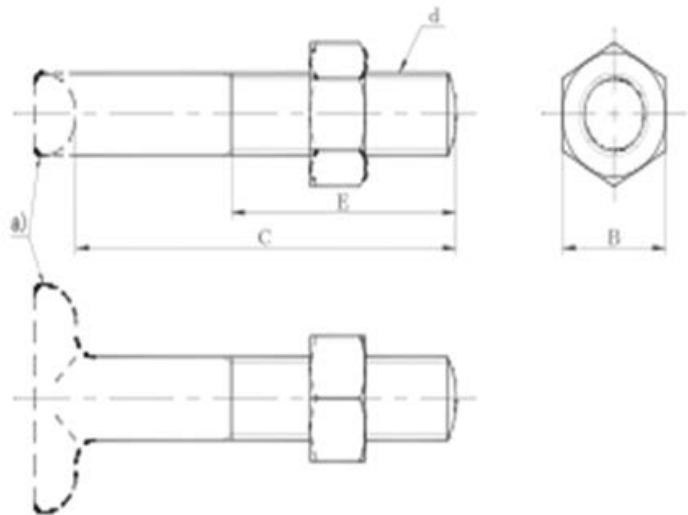

## 32. Type NS Rubber Gasket

TABLE 50 Type NS Rubber Gasket

Nominal size (mm)	D <sub>1</sub> (mm)	D <sub>2</sub> (mm)	A (mm)	B (mm)	E (mm)
75	127.6	115.6	12.0	18.4	33.0
100	159.3	145.3	13.0	20.9	35.3
150	215.0	201.0	15.5	22.9	40.5
200	272.5	256.5	18.0	25.4	40.8
250	325.7	309.7	18.0	25.4	40.8

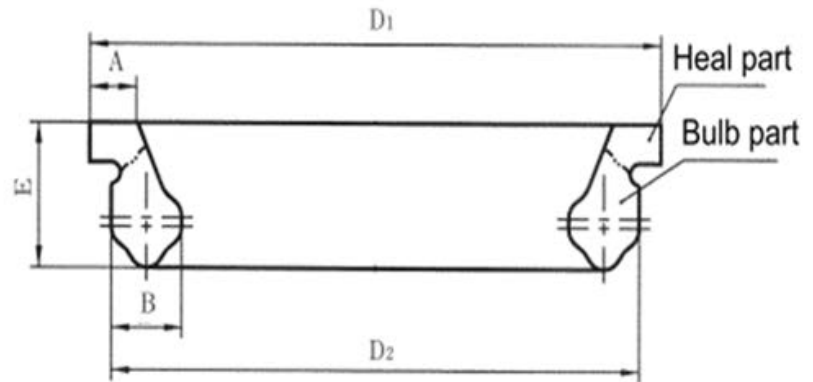
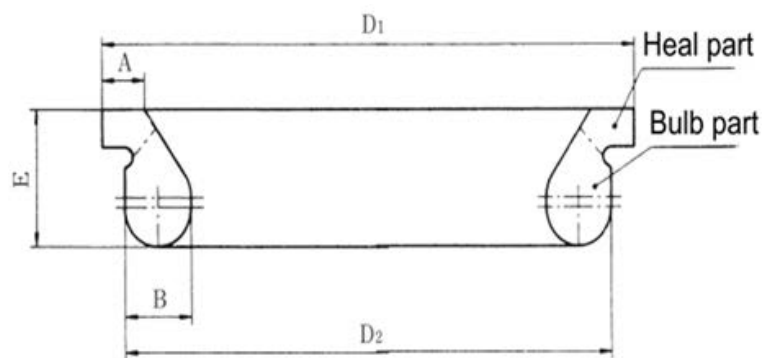

TABLE 51 Type NS Rubber Gasket

Nominal size (mm)	D <sub>1</sub> (mm)	D <sub>2</sub> (mm)	A (mm)	B (mm)	E (mm)
300	386.5	366.5	21.3	27.9	45.3
350	443.1	421.1	23.8	30.9	50.0
400	500.8	478.8	25.8	34.9	52.0
450	553.4	531.4	25.8	34.9	52.0
250	325.7	309.7	18.0	25.4	40.8



**TABLE 52** Type NS Rubber Gasket

Nominal size (mm)	D <sub>1</sub> (mm)	D <sub>2</sub> (mm)	d (mm)	L (mm)	M (mm)
75	93	87.4	15.6	46	19
100	116	110.0	17.0	46	20
150	165	159.0	17.0	46	20
200	216	210.0	17.0	46	20
250	266	260.0	17.0	46	20
300	316	310.0	18.0	47	21
350	366	360.0	18.0	47	21
400	416	410.0	18.0	47	21
450	468	462.0	18.0	47	21

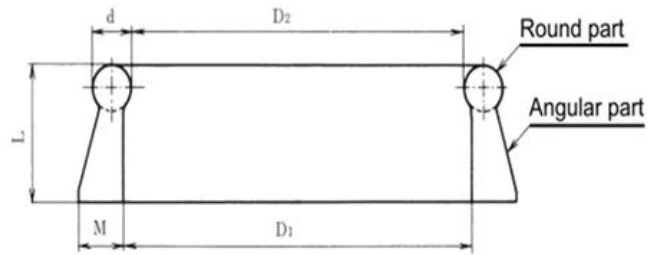

**TABLE 53** Type NS Rubber Gasket

Nominal size (mm)	D <sub>1</sub> (mm)	D <sub>2</sub> (mm)	d (mm)	L (mm)	M (mm)
500	518	512	16	51	17
600	620	614	16	51	17
700	718	710	21	61	21
800	818	809	23	67	23
900	918	909	23	67	23
1000	1018	1008	24	69	24

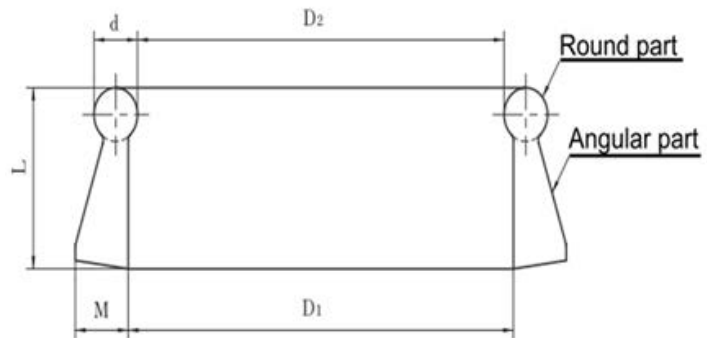

### 33. Type NS Rubber for Centring Lock Ring

TABLE 54 Type NS Rubber for Centring Lock Ring

Nominal size (mm)	Nominal size 75 to 450 for pipe Nominal size 75 to 450 for fitting				Nominal size 300 to 500 for fitting			
	Ds (mm)	B (mm)	V (mm)	Number of protrusions	Ds (mm)	B (mm)	V (mm)	Number of protrusions
75	126.6	15	3	7	-	-	-	-
100	154.8	15	3	7	-	-	-	-
150	205.9	15	3	8	-	-	-	-
200	257.2	15	3	10	-	-	-	-
250	309.0	15	3	12	-	-	-	-
300	362.4	21	3	14	366.4	21	2	8
350	414.3	21	3	16	418.4	21	2	10
400	466.0	21	3	18	469.1	21	2	10
450	517.4	21	3	20	520.5	21	2	12

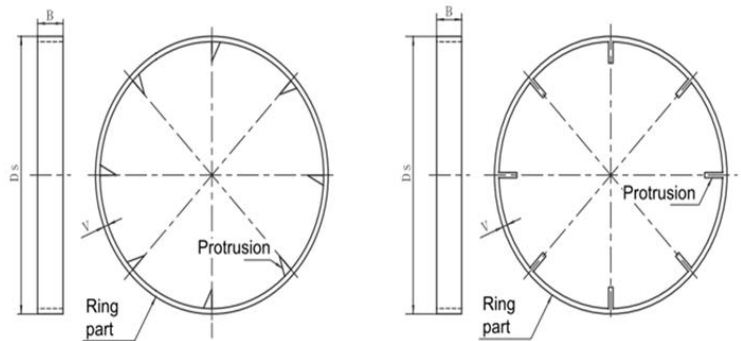

### 34. Type NS Rubber for Centring Liner

TABLE 55 Type NS Rubber for Centring Liner

Nominal size (mm)	D <sub>9</sub> (mm)	A (mm)	B (mm)
75	116	55	9.0
100	144	55	9.5
150	195	80	10.5
200	246	80	10.5
250	296	80	10.5
300	349	100	13.5
350	400	100	13.5
400	452	105	13.5
450	503	105	13.5

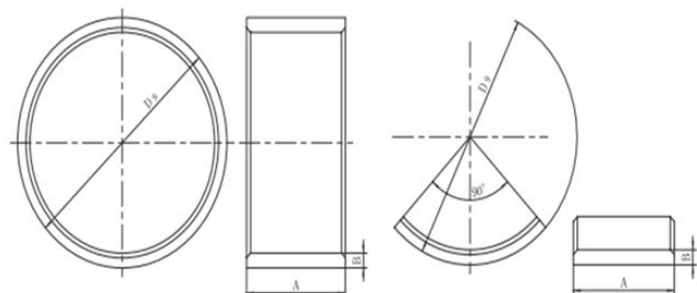

### 35. Type NS Backup Ring

**TABLE 56** Type NS Backup Ring

Nominal size (mm)	R (mm)	h (mm)	m (mm)
75	46.5	9	11
100	59.0	10	12
150	84.5	10	12
200	110.0	10	12
250	136.0	10	12
300	161.5	11	13
350	187.0	11	13
400	213.0	11	13
450	238.5	11	13

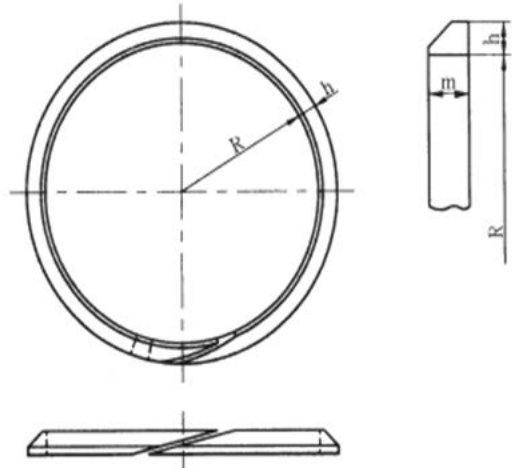

**TABLE 57** Type NS Backup Ring

Nominal size (mm)	L (mm)	h (mm)	m (mm)	n (mm)
500	1696	6	9	11.0
600	2019	6	9	11.0
700	2353	8	9	13.5
800	2677	8	9	13.5
900	3000	8	9	13.5
1000	3321	8	9	13.5

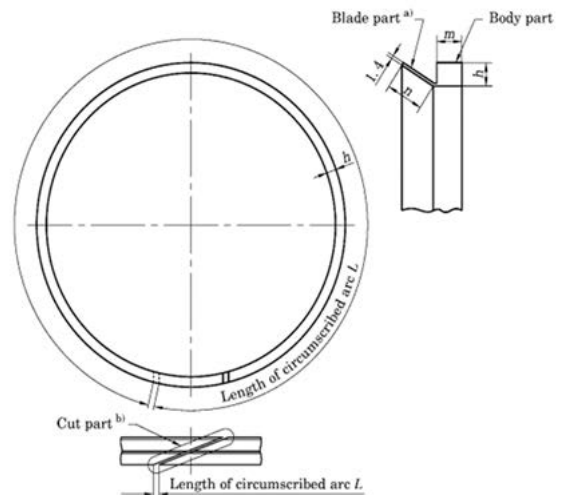

## Connecting to JIS from AS/NZS4087

### Double flanged adaptor (JIS to AS4087)

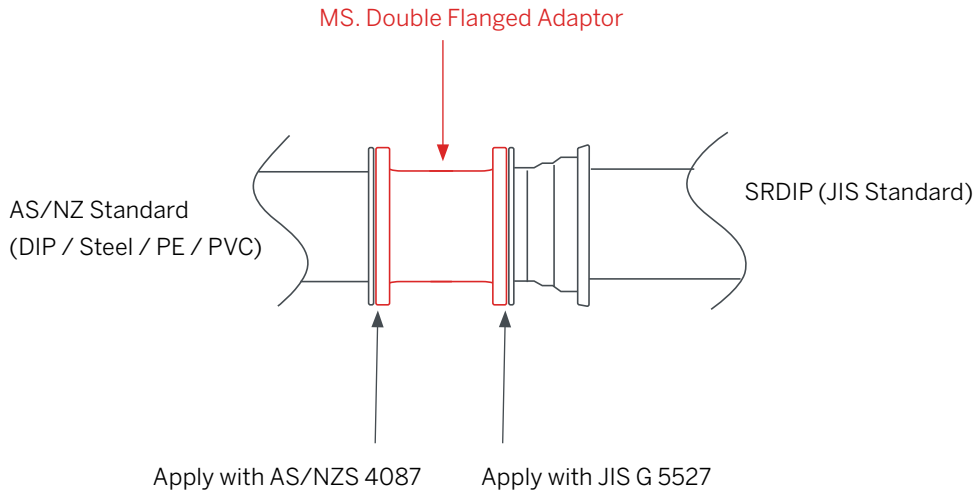

### Flange spigot adaptor to Type NS pipe-socket

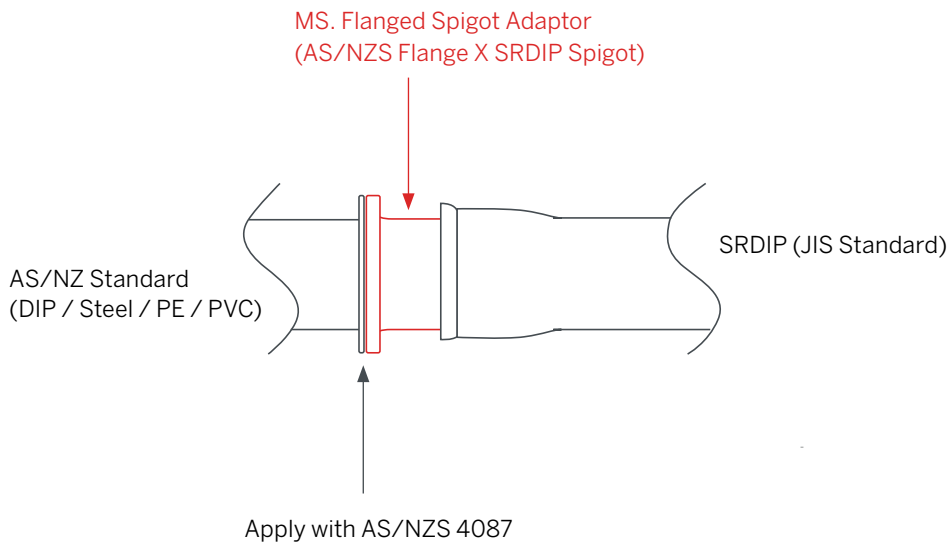

# TOOLSETS



No.1: 0.3mm thickness gauge



No.2 - 10: Joint ring set



No.11 - 12: Hydraulic cylinder set



No.13: Manual type hydraulic pump No j-35



No.14: Lock ring expander for fitting



No.15: Lock ring stopper for fitting 100mm X 85mm



No.16: Backup ring insertion tool



No.18: Lock ring dismantling tool



No.19: 0.5mm thickness gauge



No.20: NS510 Basic tool set



No.21-22: Type NS Groover: Cutting machine & Grooving machine



No.25-33: Type NS Groover Guide ring



No.34: Drill bit with stopper



No.35: Spigot ring expander



No.36-37: Depth check gauge A & B



No.38: G-clamp BC38E



No.39: Pipe stand (H) with aluminium rollers



No.40: Flexible-drive cutting machine main unit – Keel Cutter N600LRC

---



No.41: Engine unit for flexible drive cutting machine



No.42: Flexible shaft (6 m)



No.43-48: Keel cutter Guide ring

---



No.49: Diamond blade 150 x 3S



No.50-53: Grooving blade



No.54: Water tank (12 L)

---



No.55: Pipe support (large), with 2 aluminum roller assemblies



No.56: Wedge for preventing diamond blade pinching

---



No.57: Rubber gasket dismantling tool



No.58: Dismantling rod supplement tool

---

# NEW ZEALAND CASE STUDIES

## SRDIP Projects in New Zealand (as of February 2026)

### Disaster Resilient Ductile Iron Pipe

Kaitoke - Bridge Mounted DN1500



Porirua - 800m of DN400



Grasmere and Dulles Place, Canterbury DN350



Colombo Street 450m of DN200

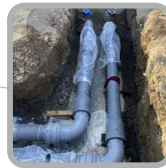

Heathcote Valley - 3km of DN350 Water Main



Greenfield Project 4km of DN150



## Kaitoke Flume Bridge (Wellington Water)

The bulk water, bridge mounted water transmission pipeline has been commissioned at the isolated Kaitoke Bridge construction site.



## Heathcote Valley (Christchurch City Council)

Contractor: Utility Infrastructure NZ

- 2.7km DN350 SRDI Pipe
- Three Separable Portions.
- Project:
  - I. Start – July 2022.
  - II. Finish of SP 1&2 April 2023.
  - III. Final completion April 2025.



## Greenfield Water Supply (Clutha District Council)

New Zealand's first installation.

- 4km DN150 PN30 SRDIP
- Part of a 38 km water pipeline
- Potable drinking water to the town of Lawrence Central Otago.
- An open country pipeline up to 40 joints assembled per day.





Scan for more  
information

**Disclaimer:** While every effort has been made to ensure that the information in this document is correct and accurate, users of Hygrade Water Infrastructure product or information within this document must make their own assessment of suitability for their particular application. Product dimensions are nominal only, and should be verified if critical to a particular installation. No warranty is either expressed, implied, or statutory made by Hygrade Water Infrastructure unless expressly stated in any sale and purchase agreement entered into between Hygrade Water Infrastructure and the user.

**April 2026**

**+61 7 38059186**  
**hygradewater.com.au**

**BRISBANE** (Head Office) 42-44 Blue Eagle Drive, Meadowbrook, QLD 4131  
**SYDNEY** 2/35 Prime Dr, Seven Hills NSW 2147, Australia  
**MELBOURNE** 20A Frances Drive, Dandenong South 3175

**HW** **HYGRADE WATER**  
INFRASTRUCTURE