

Ductile Iron Tees – Flanged

The Gillies range of ductile iron fittings are manufactured to the highest industry standards and have a proven performance record in Australia.



TECHNICAL GUIDE: **APF1.5**

Applications

Potable water and
wastewater pipelines

Water reticulation and irrigation

Water supply maintenance

Subdivisions

Pump stations

Product Attributes

High-strength ductile iron
construction

Plascoat coated

Installed above and below ground

Approvals/Standards

Approved to AS/NZ 2280 standard

Coating complies with
AS/NZS 4158 and 4020
(WSAA Product Appraisal 05/12)

Quality

ISO 9001:2008 Quality
Management Standard

The Gillies range of ductile iron fittings are manufactured to the highest industry standards and have a proven performance record in Australia.

Design Specifications

- Sizes available from 80 - 600mm
- Operating pressure up to 1600kPA as standard. Higher pressure available.
- Suitable for in-ground and above ground applications
- All fittings have a plascoat coating for superior protection.

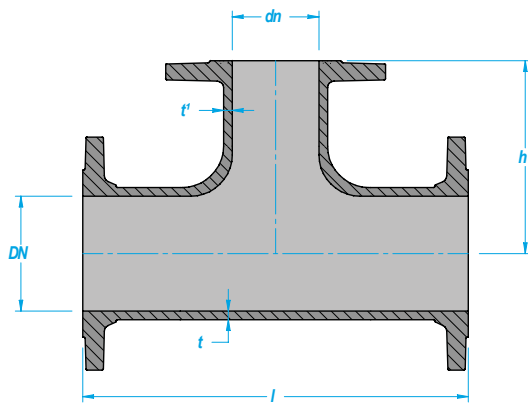

FIG. 1 TEES FLG/FLG/FLG

TABLE 1 Dimensions

Nominal Size		h (mm)	l (mm)
DN (mm)	dn (mm)		
100	100	178	356
150	100	203	406
150	150	203	406
200	100	241	484
200	150	241	484
200	200	241	484
250	100	267	534
250	150	267	534
250	200	267	534
250	225	267	534
250	250	267	534
300	100	305	610
300	150	305	610
300	200	305	610
300	250	305	610
300	300	305	610
375	200	356	738
375	225	356	738
375	250	356	738
375	300	356	738
375	375	368	738
450	250	394	814
450	300	394	814
450	375	406	814
450	450	406	814
500	250	432	890
500	300	432	890
500	375	444	890
500	450	444	890
500	500	444	890
600	300	483	890
600	375	495	1016
600	450	495	1016
600	500	495	1016
600	600	508	1016



Scan for more information

Disclaimer: While every effort has been made to ensure that the information in this document is correct and accurate, users of Hygrade Water Infrastructure product or information within this document must make their own assessment of suitability for their particular application. Product dimensions are nominal only, and should be verified if critical to a particular installation. No warranty is either expressed, implied, or statutory made by Hygrade Water Infrastructure unless expressly stated in any sale and purchase agreement entered into between Hygrade Water Infrastructure and the user. **March 2024**