

Ductile Iron Tees – Socket

The Gillies range of ductile iron fittings are manufactured to the highest industry standards and have a proven performance record in Australia.



TECHNICAL GUIDE: **APF1.4**

Applications

Potable water and
wastewater pipelines

Water reticulation and irrigation

Water supply maintenance

Subdivisions

Pump stations

Product Attributes

High-strength ductile iron
construction

Bureau Veritas S Mark accredited

Plascoat coated

Installed above and below ground

Approvals/Standards

Approved to AS/NZ 2280 Standard

Coating to AS/NZS 4158 &
AS/NZS 4020 (WSAA Product
Appraisal 05/12)

Quality

ISO 9001:2008 Quality
Management Standard

The Gillies range of ductile iron fittings are manufactured to the highest industry standards and have a proven performance record in Australia.

Design Specifications

- Sizes available from 80-600mm
- Operating pressure up to 1600kPa as standard. Higher pressures available.
- Maximum deflection 3.5deg
- All fittings have a plascoat coating for superior protection
- Suitable for in-ground and above ground applications

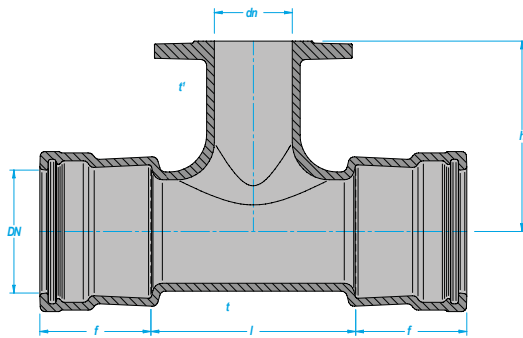

FIG. 1 Tee SOC/SOC/FLG

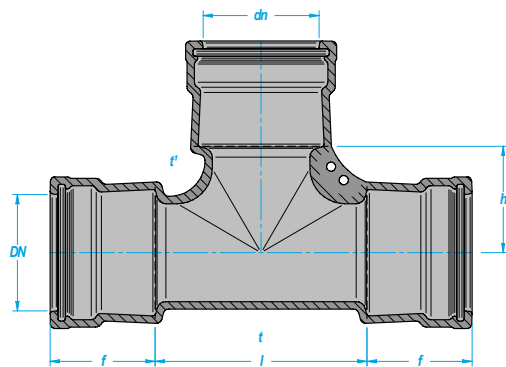

FIG. 2 Tee SOC/SOC/SOC

TABLE 1 Dimensions

Nominal Size		h (mm)	l (mm)
DN (mm)	dn (mm)		
100	100	115	230
150	100	145	230
150	150	145	290
200	100	170	230
200	150	170	290
200	200	170	340
250	100	200	240
250	150	200	300
250	200	200	350
250	250	205	410
300	100	230	240
300	150	230	300
300	200	230	50
300	250	235	410
300	300	245	490
375	200	270	360
375	225	275	390
375	250	275	420
375	350	285	500
375	375	305	610
450	250	315	420
450	300	325	500
450	375	345	610
450	450	345	690
500	250	340	420
500	300	355	500
500	375	370	610
500	450	370	690
500	500	385	770
600	300	405	500
600	375	425	610
600	450	425	690
600	500	435	770
600	600	435	870



Scan for more information

Disclaimer: While every effort has been made to ensure that the information in this document is correct and accurate, users of Hygrade Water Infrastructure product or information within this document must make their own assessment of suitability for their particular application. Product dimensions are nominal only, and should be verified if critical to a particular installation. No warranty is either expressed, implied, or statutory made by Hygrade Water Infrastructure unless expressly stated in any sale and purchase agreement entered into between Hygrade Water Infrastructure and the user.

March 2024