

DUCTILE IRON USJ FLANGE CONNECTORS

GWM09FLG-A
JUNE 2008



FEATURES & BENEFITS:

- Complies to AS/NZ 2280 Standard.
- High strength ductile iron construction.
- USJ (Universal Socket Joint) deep socket entry to suit all Series 2 pipe.
- Maximum deflection 3.5deg.
- All fittings supplied with Plascoat coating for superior protection and ease of repair.
- Coating complies to AS/NZS 4158 & 4020. (WSAA Product Appraisal 05/12).

GENERAL APPLICATIONS:

- USJ Pipeline fittings are used in the construction of new pipelines.
- For use with potable & non-potable water & waste.

TECHNICAL DATA:

- Sizes available from 100 – 150mm
- Operating pressure up to 1600kPa.

MANUFACTURED UNDER AN ISO 9001 CERTIFIED QUALITY MANAGEMENT SYSTEM

DIMENSIONS

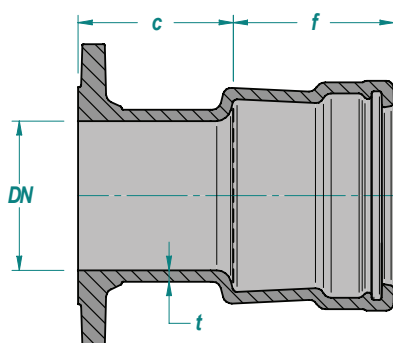

Connectors **FLG/SOC**

Table 1: Dimensions – Stated in mm

DN (mm)	t (nom)	c	f
100	8	110	114
150	9	135	121



Disclaimer: Users of the Gillies Metaltech products and/or information within this document must make their own assessment for suitability for their particular circumstances. Product dimensions and specifications may vary according to factory of manufacture or changes due to product improvements. No warranty is neither expressed nor implied nor statutory is made by Gillies Metaltech in this document unless expressly stated in any sale and purchase agreement entered into between Gillies Metaltech and the user.